



Dropping funnels, cylindrical, without pressure equalizing, graduated, ST-PTFE-stopcock, with screw-thread retaining nut, made of borosilicate glass

Ampoules cylindriques graduées, sans tubulure latérale, à 2 rodages et à robinet interchangeable en téflon, en verre borosilicaté

Capacity Capacité ml	Division Division ml	Cone Cône mâle ST	Socket Cône femelle ST	Bore of plug Voie mm	Stopcock Robinet	Order No. N° de code
25	0.5	14/23	14/23	2.5	14.5	1.810.025
50	1	14/23	14/23	2.5	14.5	1.810.050
100	2	14/23	14/23	2.5	14.5	1.810.100
250	5	14/23	14/23	4	18.8	1.810.250
50	1	19/26	19/26	2.5	14.5	1.812.050
100	2	19/26	19/26	2.5	14.5	1.812.100
250	5	19/26	19/26	4	18.8	1.812.250
500	10	19/26	19/26	4	18.8	1.812.500
50	1	24/29	24/29	2.5	14.5	1.814.050
100	2	24/29	24/29	2.5	14.5	1.814.100
250	5	24/29	24/29	4	18.8	1.814.250
500	10	24/29	24/29	4	18.8	1.814.500
1000	20	24/29	24/29	6.3	21.5	1.814.001
2000	50	24/29	24/29	6.3	21.5	1.814.002
50	1	29/32	29/32	2.5	14.5	1.816.050
100	2	29/32	29/32	2.5	14.5	1.816.100
250	5	29/32	29/32	4	18.8	1.816.250
500	10	29/32	29/32	4	18.8	1.816.500
1000	20	29/32	29/32	6.3	21.5	1.816.001
2000	50	29/32	29/32	6.3	21.5	1.816.002



1.810.***

-
1.816.***

Dropping funnels, cylindrical, without pressure equalizing, graduated, needle valve-stopcock, with PTFE-needle valve, with screw-thread retaining nut, made of borosilicate glass

Ampoules cylindriques graduées, sans tubulure latérale, à 2 rodages et à robinet à pointe en téflon, en verre borosilicaté

Capacity Capacité ml	Division Division ml	Cone Cône mâle ST	Socket Cône femelle ST	Bore of plug Voie mm	Stopcock Robinet	Order No. N° de code
25	0.5	14/23	14/23	2.5	14.5	1.828.025
50	1	14/23	14/23	2.5	14.5	1.828.050
50	1	19/26	19/26	2.5	14.5	1.827.105
100	2	19/26	19/26	2.5	14.5	1.827.110
250	5	19/26	19/26	4	18.8	1.827.125
500	10	19/26	19/26	4	18.8	1.827.150
50	1	24/29	24/29	2.5	14.5	1.827.205
100	2	24/29	24/29	2.5	14.5	1.827.210
250	5	24/29	24/29	4	18.8	1.827.225
500	10	24/29	24/29	4	18.8	1.827.250
1000	20	24/29	24/29	6.3	21.5	1.827.260
2000	50	24/29	24/29	6.3	21.5	1.827.272
50	1	29/32	29/32	2.5	14.5	1.828.051
100	2	29/32	29/32	2.5	14.5	1.828.100
250	5	29/32	29/32	4	18.8	1.828.250
500	10	29/32	29/32	4	18.8	1.828.500
1000	20	29/32	29/32	6.3	21.5	1.828.001
2000	50	29/32	29/32	6.3	21.5	1.828.002



1.827.***

-
1.828.***



1.840.***
-
1.846.***

Dropping funnels, cylindrical, with pressure equalizing tube, ungraduated, ST-stopcock, with screw-thread retaining nut, made of borosilicate glass

Ampoules cylindriques non-graduées, avec tubulure latérale, à 2 rodages et à robinet interchangeable, en verre borosilicaté

Capacity Capacité ml	Cone Cône mâle ST	Socket Cône femelle ST	Bore of plug Voie mm	Stopcock Robinet	Order No. N° de code
25	14/23	14/23	2.5	14.5	1.840.025
50	14/23	14/23	2.5	14.5	1.840.050
100	14/23	14/23	2.5	14.5	1.840.100
250	14/23	14/23	4	18.8	1.840.250
50	19/26	19/26	2.5	14.5	1.842.050
100	19/26	19/26	2.5	14.5	1.842.100
250	19/26	19/26	4	18.8	1.842.250
500	19/26	19/26	4	18.8	1.842.500
50	24/29	24/29	2.5	14.5	1.844.050
100	24/29	24/29	2.5	14.5	1.844.100
250	24/29	24/29	4	18.8	1.844.250
500	24/29	24/29	4	18.8	1.844.500
1000	24/29	24/29	6.3	21.5	1.844.001
2000	24/29	24/29	6.3	21.5	1.844.002
50	29/32	29/32	2.5	14.5	1.846.050
100	29/32	29/32	2.5	14.5	1.846.100
250	29/32	29/32	4	18.8	1.846.250
500	29/32	29/32	4	18.8	1.846.500
1000	29/32	29/32	6.3	21.5	1.846.001
2000	29/32	29/32	6.3	21.5	1.846.002



1.850.***
-
1.856.***

Dropping funnels, acc. to DIN 12567 cylindrical, with pressure equalizing tube, graduated, ST-stopcock, with screw-thread retaining nut, made of borosilicate glass

Ampoules cylindriques graduées, avec tubulure latérale, à 2 rodages et à robinet interchangeable, en verre borosilicaté

Capacity Capacité ml	Division Division ml	Cone Cône mâle ST	Socket Cône femelle ST	Bore of plug Voie mm	Stopcock Robinet	Order No. N° de code
25	0.5	14/23	14/23	2.5	14.5	1.850.025
50	1	14/23	14/23	2.5	14.5	1.850.050
100	2	14/23	14/23	2.5	14.5	1.850.100
250	5	14/23	14/23	4	18.8	1.850.250
50	1	19/26	19/26	2.5	14.5	1.852.050
100	2	19/26	19/26	2.5	14.5	1.852.100
250	5	19/26	19/26	4	18.8	1.852.250
500	10	19/26	19/26	4	18.8	1.852.500
50	1	24/29	24/29	2.5	14.5	1.854.050
100	2	24/29	24/29	2.5	14.5	1.854.100
250	5	24/29	24/29	4	18.8	1.854.250
500	10	24/29	24/29	4	18.8	1.854.500
1000	20	24/29	24/29	6.3	21.5	1.854.001
2000	50	24/29	24/29	6.3	21.5	1.854.002
50	1	29/32	29/32	2.5	14.5	1.856.050
100	2	29/32	29/32	2.5	14.5	1.856.100
250	5	29/32	29/32	4	18.8	1.856.250
500	10	29/32	29/32	4	18.8	1.856.500
1000	20	29/32	29/32	6.3	21.5	1.856.001
2000	50	29/32	29/32	6.3	21.5	1.856.002



Dropping funnels, cylindrical, with pressure equalizing tube, graduated, ST-PTFE-stopcock, with screw-thread retaining nut, made of borosilicate glass

Ampoules cylindriques graduées, avec tubulure latérale, à 2 rodages et à robinet interchangeable en téflon, en verre borosilicaté

Capacity Capacité ml	Division Division ml	Cone Cône mâle ST	Socket Cône femelle ST	Bore of Plug Voie mm	Stopcock Robinet	Order No. N° de code
25	0.5	14/23	14/23	2.5	14.5	1.860.025
50	1	14/23	14/23	2.5	14.5	1.860.050
100	2	14/23	14/23	2.5	14.5	1.860.100
250	5	14/23	14/23	4	18.8	1.860.250
50	1	19/26	19/26	2.5	14.5	1.862.050
100	2	19/26	19/26	2.5	14.5	1.862.100
250	5	19/26	19/26	4	18.8	1.862.250
500	10	19/26	19/26	4	18.8	1.862.500
50	1	24/29	24/29	2.5	14.5	1.864.050
100	2	24/29	24/29	2.5	14.5	1.864.100
250	5	24/29	24/29	4	18.8	1.864.250
500	10	24/29	24/29	4	18.8	1.864.500
1000	20	24/29	24/29	6.3	21.5	1.864.001
2000	50	24/29	24/29	6.3	21.5	1.864.002
50	1	29/32	29/32	2.5	14.5	1.866.050
100	2	29/32	29/32	2.5	14.5	1.866.100
250	5	29/32	29/32	4	18.8	1.866.250
500	10	29/32	29/32	4	18.8	1.866.500
1000	20	29/32	29/32	6.3	21.5	1.866.001
2000	50	29/32	29/32	6.3	21.5	1.866.002

Dropping funnels, cylindrical, with pressure equalizing tube, graduated, needle valve-stopcock, with PTFE-needle valve, with screw-thread retaining nut, made of borosilicate glass

Ampoules cylindriques graduées, avec tubulure latérale, à 2 rodages coniques et à robinet à pointe en téflon, en verre borosilicaté

Capacity Capacité ml	Division Division ml	Cone Cône mâle ST	Socket Cône femelle ST	Bore of Plug Voie mm	Stopcock Robinet	Order No. N° de code
50	1	14/23	14/23	2.5	14.5	1.869.050
50	1	19/26	19/26	2.5	14.5	1.868.105
100	2	19/26	19/26	2.5	14.5	1.868.110
250	5	19/26	19/26	4	18.8	1.868.125
500	10	19/26	19/26	4	18.8	1.868.150
50	1	24/29	24/29	2.5	14.5	1.868.205
100	2	24/29	24/29	2.5	14.5	1.868.210
250	5	24/29	24/29	4	18.8	1.868.225
500	10	24/29	24/29	4	18.8	1.868.250
1000	20	24/29	24/29	6.3	21.5	1.868.261
2000	50	24/29	24/29	6.3	21.5	1.868.272
25	0.5	14/23	14/23	2.5	14.5	1.869.025
50	1	29/32	29/32	2.5	14.5	1.869.051
100	2	29/32	29/32	2.5	14.5	1.869.100
250	5	29/32	29/32	4	18.8	1.869.250
500	10	29/32	29/32	4	18.8	1.869.500
1000	20	29/32	29/32	6.3	21.5	1.869.001
2000	50	29/32	29/32	6.3	21.5	1.869.002



1.860.***

-

1.866.***

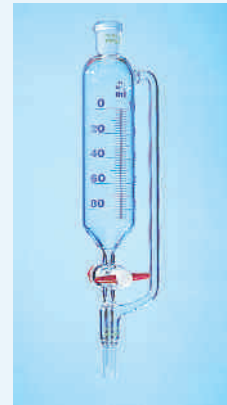

1.869.***



1.886.***
-
1.892.***

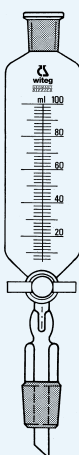

1.893.***

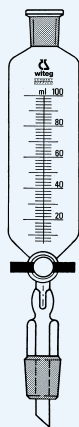

1.893.1**

Dropping funnels, round bottom, ungraduated, ST-stopcock, with screw-thread retaining nut, made of borosilicate glass

Ampoules à décanter sphériques à rodages, non-graduées, avec robinet interchangeable, en verre borosilicaté

Capacity Capacité ml	Cone Cône mâle ST	Socket Cône femelle ST	Bore of Plug Voie mm	Stopcock Robinet	Order No. N° de code
25	14/23	14/23	2.5	14.5	1.886.025
50	14/23	14/23	2.5	14.5	1.886.050
100	14/23	14/23	2.5	14.5	1.886.100
250	14/23	14/23	4	18.8	1.886.250
50	19/26	19/26	2.5	14.5	1.888.050
100	19/26	19/26	2.5	14.5	1.888.100
250	19/26	19/26	4	18.8	1.888.250
500	19/26	19/26	4	18.8	1.888.500
50	24/29	24/29	2.5	14.5	1.890.050
100	24/29	24/29	2.5	14.5	1.890.100
250	24/29	24/29	4	18.8	1.890.250
500	24/29	24/29	4	18.8	1.890.500
1000	24/29	24/29	6.3	21.5	1.890.001
2000	24/29	24/29	6.3	21.5	1.890.002
50	29/32	29/32	2.5	14.5	1.892.050
100	29/32	29/32	2.5	14.5	1.892.100
250	29/32	29/32	4	18.8	1.892.250
500	29/32	29/32	4	18.8	1.892.500
1000	29/32	29/32	6.3	21.5	1.892.001
2000	29/32	29/32	6.3	21.5	1.892.002

Dropping funnels, cylindrical, with drip-nozzle, without pressure equalizing, graduated, ST-stopcock, with screw-thread retaining nut, made of borosilicate glass

Ampoules cylindriques graduées à gouttière, sans tubulure, à rodages, avec robinet interchangeable, en verre borosilicaté

Capacity Capacité ml	Division Division ml	Cone Cône mâle ST	Socket Cône femelle ST	Bore of Plug Voie mm	Stopcock Robinet	Order No. N° de code
10	0.2	14/23	14/23	2.5	14.5	1.893.001
25	0.5	14/23	14/23	2.5	14.5	1.893.002
50	1	14/23	14/23	2.5	14.5	1.893.003
100	2	14/23	14/23	2.5	14.5	1.893.013
50	1	29/32	29/32	2.5	14.5	1.893.004
100	2	29/32	29/32	2.5	14.5	1.893.005
250	5	29/32	29/32	4	18.8	1.893.006
500	10	29/32	29/32	4	18.8	1.893.007
1000	20	29/32	29/32	6.3	21.5	1.893.008
2000	50	29/32	29/32	6.3	21.5	1.893.009

Dropping funnels, cylindrical, with drip-nozzle, without pressure equalizing, graduated, ST-PTFE-stopcock, with screw-thread retaining nut, made of borosilicate glass

Ampoules cylindriques graduées à gouttière, sans tubulure, à rodages, avec robinet interchangeable en téflon, en verre borosilicaté

Capacity Capacité ml	Division Division ml	Cone Cône mâle ST	Socket Cône femelle ST	Bore of Plug Voie mm	Stopcock Robinet	Order No. N° de code
10	0.2	14/23	14/23	2.5	14.5	1.893.101
25	0.5	14/23	14/23	2.5	14.5	1.893.102
50	1	14/23	14/23	2.5	14.5	1.893.103
100	2	14/23	14/23	2.5	14.5	1.893.113
50	1	29/32	29/32	2.5	14.5	1.893.104
100	2	29/32	29/32	2.5	14.5	1.893.105
250	5	29/32	29/32	4	18.8	1.893.106
500	10	29/32	29/32	4	18.8	1.893.107
1000	20	29/32	29/32	6.3	21.5	1.893.108
2000	50	29/32	29/32	6.3	21.5	1.893.109



Dropping funnels, cylindrical, with drip-nozzle, with pressure equalizing, graduated, ST-stopcock, with screw-thread retaining nut, made of borosilicate glass

Ampoules cylindriques graduées à gouttière et tubulure, à rodages, avec robinet interchangeable, en verre borosilicaté

Capacity Capacité	Division Division	Cone Cône mâle	Socket Cône femelle	Bore of Plug Voie	Stopcock Robinet	Order No. N° de code
ml	ml	ST	ST	mm		
10	0.2	14/23	14/23	2.5	14.5	1.895.001
25	0.5	14/23	14/23	2.5	14.5	1.895.002
50	1	14/23	14/23	2.5	14.5	1.895.003
100	2	14/23	14/23	2.5	14.5	1.895.013
10	0.2	19/26	19/26	2.5	14.5	1.895.021
25	0.5	19/26	19/26	2.5	14.5	1.895.022
50	1	19/26	19/26	2.5	14.5	1.895.023
100	2	19/26	19/26	2.5	14.5	1.895.024
50	1	29/32	29/32	2.5	14.5	1.895.004
100	2	29/32	29/32	2.5	14.5	1.895.005
250	5	29/32	29/32	4	18.8	1.895.006
500	10	29/32	29/32	4	18.8	1.895.007
1000	20	29/32	29/32	6.3	21.5	1.895.008
2000	50	29/32	29/32	6.3	21.5	1.895.009

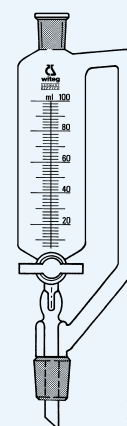

1.895.***

Dropping funnels, cylindrical, with drip-nozzle, with pressure equalizing, graduated, ST-PTFE-stopcock, with screw-thread retaining nut, made of borosilicate glass

Ampoules cylindriques graduées à gouttière et tubulure, à rodages, avec robinet interchangeable en téflon, en verre borosilicaté

Capacity Capacité	Division Division	Cone Cône mâle	Socket Cône femelle	Bore of Plug Voie	Stopcock Robinet	Order No. N° de code
ml	ml	ST	ST	mm		
10	0.2	14/23	14/23	2.5	14.5	1.895.101
25	0.5	14/23	14/23	2.5	14.5	1.895.102
50	1	14/23	14/23	2.5	14.5	1.895.103
100	2	14/23	14/23	2.5	14.5	1.895.113
10	0.2	19/26	19/26	2.5	14.5	1.895.121
25	0.5	19/26	19/26	2.5	14.5	1.895.122
50	1	19/26	19/26	2.5	14.5	1.895.123
100	2	19/26	19/26	2.5	14.5	1.895.124
50	1	29/32	29/32	2.5	14.5	1.895.104
100	2	29/32	29/32	2.5	14.5	1.895.105
250	5	29/32	29/32	4	18.8	1.895.106
500	10	29/32	29/32	4	18.8	1.895.107
1000	20	29/32	29/32	6.3	21.5	1.895.108
2000	50	29/32	29/32	6.3	21.5	1.895.109

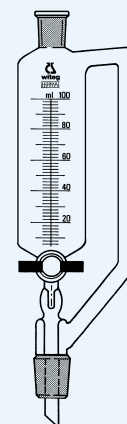

1.895.1**

Dropping funnels at connecting piece, cylindrical, graduated, stopcock 14.5, made of borosilicate glass

Ampoules graduées cylindriques à raccord latéral à rodage, en verre borosilicaté

Capacity Capacité	Division Division	Connecting piece Cône mâle	Funnel socket Cône femelle	Order No. N° de code
ml	ml	ST	ST	
50	1	14/23	14/23	1.896.050
50	1	29/32	14/23	1.896.051
100	2	14/23	14/23	1.896.100
100	2	29/32	14/23	1.896.101

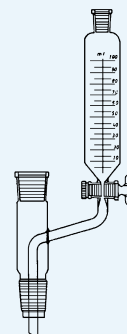

1.896.***



1.897.7**



1.897.8**



1.900.***



1.902.***

1.903.***

Funnels for solids, for powdery substances, vertical version with cooled lower part to avoid sticking problems of the spiral conveyor, made of borosilicate glass

Capacity <i>Capacité</i> ml	Cone <i>Cône mâle</i> ST	Socket <i>Cône femelle</i> ST	Order No. <i>N° de code</i>
50	29/32	29/32	1.897.775
100	29/32	29/32	1.897.776
250	29/32	29/32	1.897.777
500	29/32	29/32	1.897.778
1000	29/32	29/32	1.897.779

Ampoules cylindriques pour solides, à rodages, version à serpentín vertical, en verre borosilicaté

Funnels for solids, for powdery substances, spiral conveyor, horizontal version, made of borosilicate glass

Capacity <i>Capacité</i> ml	Cone <i>Cône mâle</i> ST	Socket <i>Cône femelle</i> ST	Order No. <i>N° de code</i>
50	29/32	29/32	1.897.805
100	29/32	29/32	1.897.810
250	29/32	29/32	1.897.825
500	29/32	29/32	1.897.850
1000	29/32	29/32	1.897.890

Ampoules cylindriques pour solides, à rodages, version à serpentín horizontal, en verre borosilicaté

Delivery adapters

Allonges à distiller

Delivery adapters, straight, made of borosilicate glass

Socket <i>Cône femelle</i> ST	Tube length <i>Longueur du tube</i> mm	Order No. <i>N° de code</i>
14/23	80	1.900.014
19/26	80	1.900.019
24/29	100	1.900.024
29/32	100	1.900.029

Allonges à distiller droites, à rodage femelle, en verre borosilicaté

Delivery adapters, bent, made of borosilicate glass

Socket <i>Cône femelle</i> ST	Tube length <i>Longueur du tube</i> mm	Order No. <i>N° de code</i>
14/23	80	1.902.014
19/26	80	1.902.019
24/29	100	1.902.024
29/32	100	1.902.029

Allonges à distiller coudées, à rodage femelle, en verre borosilicaté

Delivery adapters, bent, with long tube, made of borosilicate glass

Socket <i>Cône femelle</i> ST	Tube length <i>Longueur du tube</i> mm	Order No. <i>N° de code</i>
14/23	190	1.903.014
19/26	200	1.903.019
24/29	200	1.903.024
29/32	200	1.903.029

Allonges à distiller coudées, à rodage femelle, en verre borosilicaté, tube long



Receiving adapters

Allonges à rodages normalisés

Receiving adapters, straight, with suction tube, made of borosilicate glass

Allonges droites à rodages normalisés avec olive de raccordement au vide, en verre borosilicaté

Socket	Cone	Order No.
<i>Cône femelle</i>	<i>Cône mâle</i>	<i>N° de code</i>
ST	ST	
14/23	14/23	1.904.014
19/26	19/26	1.904.019
19/26	24/29	1.904.020
24/29	24/29	1.904.024
19/26	29/32	1.904.025
29/32	29/32	1.904.029



1.904.***

Receiving adapters, straight, with SVS hose connection, made of borosilicate glass

Allonges droites à rodages normalisés avec olive à raccord SVS, en verre borosilicaté

Socket	Cone	Order No.
<i>Cône femelle</i>	<i>Cône mâle</i>	<i>N° de code</i>
ST	ST	
14/23	14/23	1.904.014 S
19/26	19/26	1.904.019 S
19/26	24/29	1.904.020 S
24/29	24/29	1.904.024 S
19/26	29/32	1.904.025 S
29/32	29/32	1.904.029 S

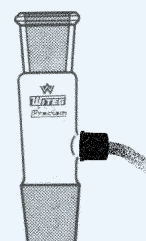

1.904.*** S

Receiving adapters, bent, with vacuum connection, made of borosilicate glass

Allonges coudées à rodages normalisés avec olive de raccordement au vide, en verre borosilicaté

Socket	Cone	Order No.
<i>Cône femelle</i>	<i>Cône mâle</i>	<i>N° de code</i>
ST	ST	
14/23	14/23	1.905.014
19/26	19/26	1.905.019
19/26	24/29	1.905.020
24/29	24/29	1.905.024
19/26	29/32	1.905.025
29/32	29/32	1.905.029



1.905.***

Receiving adapters, bent, with SVS hose connection, made of borosilicate glass

Allonges coudées à rodages normalisés avec olive à raccordement SVS, en verre borosilicaté

Socket	Cone	Order No.
<i>Cône femelle</i>	<i>Cône mâle</i>	<i>N° de code</i>
ST	ST	
14/23	14/23	1.905.014 S
19/26	19/26	1.905.019 S
19/26	24/29	1.905.020 S
24/29	24/29	1.905.024 S
19/26	29/32	1.905.025 S
29/32	29/32	1.905.029 S

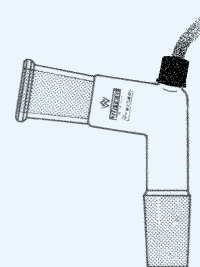

1.905.*** S



1.906.***



1.906.*** S



1.908.***



1.908.*** S

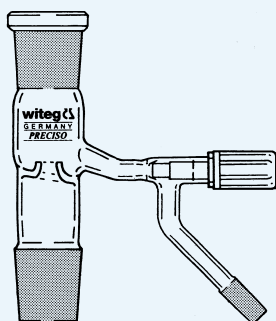

1.910.***

Receiving adapters, bent, with vacuum connection and drip tip, made of borosilicate glass

Allonges coudées à rodages normalisés avec olive de raccordement au vide et gouttière, en verre borosilicaté

Socket Cône femelle ST	Cone Cône mâle ST	Order No. N° de code
14/23	14/23	1.906.014
19/26	19/26	1.906.019
19/26	24/29	1.906.020
24/29	24/29	1.906.024
19/26	29/32	1.906.025
29/32	29/32	1.906.029

Receiving adapters, bent, with SVS hose connection and drip tip, made of borosilicate glass

Allonges coudées à rodages normalisés avec olive à raccord SVS et gouttière, en verre borosilicaté

Socket Cône femelle ST	Cone Cône mâle ST	Order No. N° de code
14/23	14/23	1.906.014 S
19/26	19/26	1.906.019 S
19/26	24/29	1.906.020 S
24/29	24/29	1.906.024 S
19/26	29/32	1.906.025 S
29/32	29/32	1.906.029 S

Receiving adapters, straight, with vacuum connection and drip tip, made of borosilicate glass

Allonges droites à rodages normalisés avec olive de raccordement au vide et gouttière, en verre borosilicaté

Socket Cône femelle ST	Cone Cône mâle ST	Order No. N° de code
14/23	14/23	1.908.014
19/26	19/26	1.908.019
24/29	24/29	1.908.024
29/32	29/32	1.908.029

Receiving adapters, straight, with SVS hose connection and drip tip, made of borosilicate glass

Allonges droites à rodages normalisés avec olive à raccordSVSe et gouttière, en verre borosilicaté

Socket Cône femelle ST	Cone Cône mâle ST	Order No. N° de code
14/23	14/23	1.908.014 S
19/26	19/26	1.908.019 S
24/29	24/29	1.908.024 S
29/32	29/32	1.908.029 S

Distilling link acc. to Dr. Horwotka, for quick change from reflux distillation to down stream distillation and opposite, with PTFE valve stopcock 6 mm, made of borosilicate glass

Raccords de distillation selon Dr. Horwotka en verre borosilicaté, pour passage rapide de la distillation à reflux à la distillation à vapeur basse et vice-versa, avec robinet à pointeau en téflon de 6 mm

Socket Cône femelle ST	Cone Cône mâle ST	Cone lateral Rodage conique mâle latéral ST	Order No. N° de code
14/23	14/23	14/23	1.910.001
29/32	29/32	14/23	1.910.002

Distilling link, with PTFE stopcock ST 14.5/2.5, made of borosilicate glass

Raccords de distillation selon Dr. Horwotka en verre borosilicaté, pour passage rapide de la distillation à reflux à la distillation à vapeur basse et vice-versa, avec robinet à clé en téflon 14.5/2.5

Socket Cône femelle ST	Cone Cône mâle ST	Cone lateral Rodage conique mâle latéral ST	Order No. N° de code
14/23	14/23	14/23	1.910.101
29/32	29/32	14/23	1.910.102



Distilling receivers

Séparateurs

Distilling receivers, Bredt, complete with adapter, distributor and 4 flask-round bottom ST 14/23, made of borosilicate glass

Séparateurs de Bredt (ou de Pauly) avec prise de vide, en verre borosilicaté, complet avec 4 ballons à fond rond et à RIN 14/23

Condenser socket <i>Cône femelle</i> ST	Distributor cone <i>Cône mâle</i> ST	Cones 4 x <i>Cône mâle</i> ST	Capacity flask <i>Capacité ballon</i> ml	Order No. <i>N° de code</i>
14/23	29/32	14/23	25	1.920.000
19/26	29/32	14/23	50	1.922.000
24/29	29/32	14/23	100	1.924.000
29/32	29/32	14/23	100	1.926.000

Adapter, flasks, made of borosilicate glass

Raccords de vide de rechange, seuls pour séparateurs, en verre borosilicaté,

Condenser Socket <i>Cône femelle</i> Réfrigérant ST	Distributor Socket <i>Raccord Separateur</i> ST	Order No. <i>N° de code</i>
14/23	29/32	1.920.001
19/26	29/32	1.922.001
24/29	29/32	1.924.001
29/32	29/32	1.926.001

Distributor, only, made of borosilicate glass

Séparateurs, de rechange, en verre borosilicaté

Distributor cone <i>Cône mâle</i> ST	Cones 4 x <i>Cône mâle</i> ST	Order No. <i>N° de code</i>
29/32	14/23	1.920.002

Flasks, round bottom, made of borosilicate glass

Ballons à fond rond de rechange, en verre borosilicaté

Socket <i>Cône femelle</i> ST	Capacity <i>Capacité</i> ml	Order No. <i>N° de code</i>
14/23	25	0.600.025
14/23	50	0.600.050
14/23	100	0.600.100

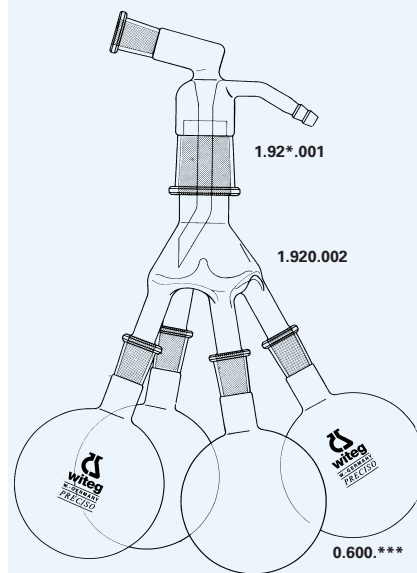

1.920.***
-
1.926.***



Distilling receivers, acc. to Bernhauer, with vacuum connection, complete with 3 flasks round bottom ST 14/23, made of borosilicate glass

Séparateurs de Bernhauer avec prise de vide, en verre borosilicaté, complet avec 3 ballons à fond rond et à RIN 14/23

Socket <i>Cône femelle</i>	Flasks capacity <i>Capacité</i>	Order No. <i>N° de code</i>
ST	ml	
14/23	50	1.930.000
19/26	100	1.932.000
24/29	100	1.934.000
29/32	100	1.936.000

Distributor, made of borosilicate glass

Séparateurs de Bernhauer, de rechange, en verre borosilicaté

Distributor cone <i>Cône mâle</i>	Cones 3x <i>Cône mâle</i>	Order No. <i>N° de code</i>
ST	ST	
14/23	14/23	1.930.001
19/26	14/23	1.932.001
24/29	14/23	1.934.001
29/32	14/23	1.936.001

Flasks, round bottom, made of borosilicate glass

Ballons à fond rond de rechange, en verre borosilicaté

Socket <i>Cône femelle</i>	Flask capacity <i>Capacité</i>	Order No. <i>N° de code</i>
ST	ml	
14/23	50	0.600.050
14/23	100	0.600.100

Intermediate receivers

Récepteurs intermédiaires de distillation

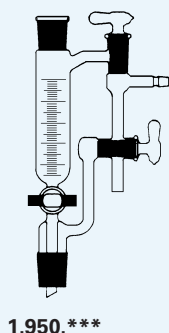

Intermediate receivers, acc. to Anschütz-Thiele, straight adapter, graduated, with hollow ST-stopcock, made of borosilicate glass

Récepteurs intermédiaires de distillation selon Anschütz-Thiele, forme droite à robinet standard, en verre borosilicaté

Capacity <i>Capacité</i>	Cone <i>Cône mâle</i>	Socket <i>Cône femelle</i>	Order No. <i>N° de code</i>
ml	ST	ST	
25	14/23	14/23	1.950.014
100	24/29	24/29	1.950.024
50	29/32	29/32	1.950.025
100	29/32	29/32	1.950.029

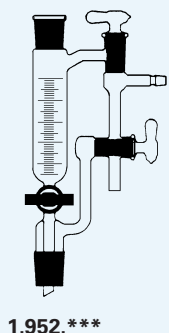

Intermediate receivers, acc. to Anschütz-Thiele, straight adapter, graduated, with PTFE-valve-stopcock, made of borosilicate glass

Récepteurs intermédiaires de distillation selon Anschütz-Thiele, forme droite à robinet à clé en téflon (PTFE), en verre borosilicaté

Capacity <i>Capacité</i>	Cone <i>Cône mâle</i>	Socket <i>Cône femelle</i>	Order No. <i>N° de code</i>
ml	ST	ST	
25	14/23	14/23	1.952.014
100	24/29	24/29	1.952.024
50	29/32	29/32	1.952.025
100	29/32	29/32	1.952.029



Intermediate receivers,
acc. to Anschütz-Thiele, with oblique
adapter, graduated, with hollow
ST-stopcock, made of borosilicate glass

*Récepteurs intermédiaires de distillation selon
Anschütz-Thiele, forme coudée à robinet
standard, en verre borosilicaté*

Capacity Capacité ml	Cone Cône mâle ST	Socket Cône femelle ST	Order No. N° de code
25	14/23	14/23	1.960.014
50	24/29	19/26	1.960.019
50	24/29	24/29	1.960.024
50	29/32	29/32	1.960.025
100	29/32	29/32	1.960.029

Intermediate receivers, acc. to
Anschütz-Thiele, with oblique adapter,
graduated, with PTFE-valve-stopcock,
made of borosilicate glass

*Récepteurs intermédiaires de distillation selon
Anschütz-Thiele, forme coudée à robinet à clé en
téflon (PTFE), en verre borosilicaté*

Capacity Capacité ml	Cone Cône mâle ST	Socket Cône femelle ST	Order No. N° de code
25	14/23	14/23	1.962.014
50	24/29	19/26	1.962.019
50	24/29	24/29	1.962.024
50	29/32	29/32	1.962.025
100	29/32	29/32	1.962.029

Intermediate receivers,
acc. to Anschütz-Thiele, straight adapter,
graduated, with hollow ST-stopcock, with
cooling jacket, made of borosilicate glass
(or with water connection GL 14
x.xxx.xxx S)

*Récepteurs intermédiaires de distillation selon
Anschütz-Thiele, forme droite avec manteau de
refroidissement à robinet standard, creux, en verre
borosilicaté
(ou avec raccords à vis GL 14 x.xxx.xxx S)*

Capacity Capacité ml	Cone Cône mâle ST	Socket Cône femelle ST	Order No. N° de code	Order No. N° de code GL 14
50	29/32	29/32	1.962.119	1.962.119 S
100	29/32	29/32	1.962.129	1.962.129 S
250	29/32	29/32	1.962.139	1.962.139 S

Intermediate receivers,
acc. to Anschütz-Thiele, straight adapter,
graduated, with PTFE-stopcock, with
cooling jacket, made of borosilicate glass
(or with water connection GL 14
x.xxx.xxx S)

*Récepteurs intermédiaires de distillation selon
Anschütz-Thiele, forme droite avec manteau de
refroidissement à robinet à clé en téflon, en verre
borosilicaté
(ou avec raccords à vis GL 14 x.xxx.xxx S)*

Capacity Capacité ml	Cone Cône mâle ST	Socket Cône femelle ST	Order No. N° de code	Order No. N° de code GL 14
50	29/32	29/32	1.962.219	1.962.219 S
100	29/32	29/32	1.962.229	1.962.229 S
250	29/32	29/32	1.962.239	1.962.239 S

Distillation head, graduated, with
condenser and supply vessel, for
recycling of solvents, with screw-thread
GL 14, made of borosilicate glass

*Tête de distillation graduée pour recyclage des
solvants avec réfrigérant et réservoir de
distribution, en verre borosilicaté*

Capacity Capacité ml	Cone Cône mâle ST	Socket Cône femelle ST	Order No. N° de code
500	29/32	29/32	1.963.000

Delivery adapter, angled, with spherical
joint S 19/9, made of borosilicate glass

*Adaptateur d'alimentation incliné,
avec roadge sphérique femelle S 19/9*

Cone Cône mâle ST	Order No. N° de code
14/23	1.963.001

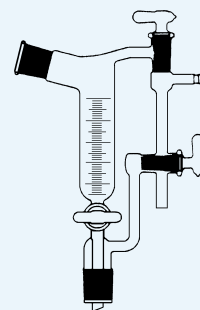

1.960.***

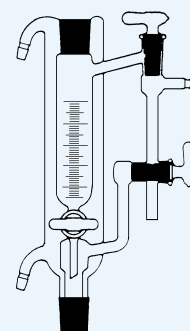

1.962.2**



With water connection
2 x GL 14 x.xxx.xxx S
(ou avec raccords à vis
2 x GL 14 x.xxx.xxx S)

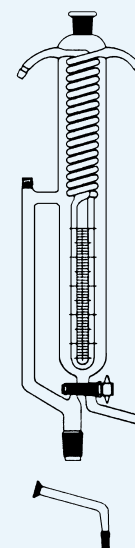

1.963.***



ST-Combi boxes

Coffrets ST d'expérimentation

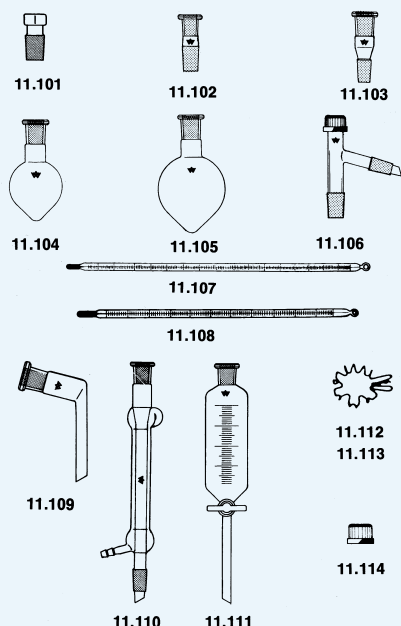

ST-Combi-Box „Semi-Mikro“ 11,
made of borosilicate glass, packed in
cardboard-box

*Kits d'expérimentation "Combi-Box" pour
différents montages de distillation / réaction,
Type semi-micro 11, en verre borosilicaté, livré
dans une boîte en carton*

Type	Order No.
Type	N° de code
Complete/Complet	11.000
Spare parts / Pièces de rechange	
1 Hollow-stopper ST 14/23	11.101
1 Reduction adapter ST 19/26 - ST 14/23	11.102
1 Expansions adapter ST 14/23 - ST 19/26	11.103
1 Flask, pear shaped, 25 ml, ST 19/26	11.104
1 Flask, pear shaped, 50 ml, ST 19/26	11.105
1 Recovery head, ST 19/26, GL 18/6, ST 14/23	11.106
1 Thermometer, solid stem, - 10 to + 250 °C : 1 °C	11.107
1 Thermometer, solid stem, - 10 to + 360 °C : 1 °C	11.108
1 Delivery Adapter, ST 14/23	11.109
1 Condenser, Liebig, 160 mm, with 2 ST 14/23	11.110
1 Dropping funnel, cylindrical, with graduation, 50 ml, ST 14/23	11.111
5 Clips for joints, ST 14/23	11.112
3 Clips for joints, ST 19/26	11.113
1 Screw cap, top closed, GL 18	11.114

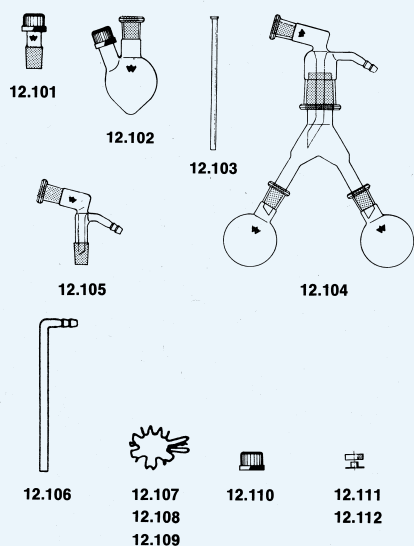

ST-Combi-Box „Semi-Mikro“ 12,
made of borosilicate glass, packed in
cardboard-box

*Kits d'expérimentation "Combi-Box" pour
différents montages de distillation / réaction,
Type semi-micro 12, en verre borosilicaté, livré
dans une boîte en carton*

Type	Order No.
Type	N° de code
Complete/Complet	12.000
Spare parts / Pièces de rechange	
1 Screw-thread, with cone, ST 19/26, GL 18/8	12.101
1 Flask, pear shaped, 50 ml, center neck ST 19/26	12.102
side neck angled with screw-thread GL 18/8	12.102
2 Air leak tubes, outer Ø 8 mm	12.103
1 Distilling receiver, Bredt, complete, adapter ST 14/23 - 29/32	12.104
distributor ST 23/32 - 14/23, 4 flasks, round, 25 ml	12.104
1 Receiver adapter, bent, with vacuum connection and drip tip, 2 ST 14/23	12.105
2 Inlet tubes at 90°, with serrated hose connector, outer Ø 8 mm	12.106
4 Clips for joints, ST 14/23	12.107
2 Clips for joints, ST 19/26	12.108
2 Clips for joints, ST 29/32	12.109
1 Screw cap, top closed, GL 18	12.110
10 Gaskets, silicone rubber, with PTFE washers 16 x 6 - GL 18	12.111
10 Gaskets, silicone rubber, with PTFE washers 16 x 8 - GL 18	12.112



ST-Combi-Box „Semi-Mikro“ 13,
made of borosilicate glass, packed in
cardboard-box

*Kits d'expérimentation "Combi-Box" pour
différents montages de distillation / réaction,
Type semi-micro 13, en verre borosilicaté, livré
dans une boîte en carton*

Type	Order No.
Type	N° de code
Complete/Complet	13.000
Spare parts / Pièces de rechange	
1 Flask, pear shaped, 100 ml, center neck ST 19/26, side neck angled with screw-thread GL 18/8, SN parallel ST 14/23	13.101
1 Inlet tube ST 14/23, outer Ø 8 mm	13.102
1 Fractionating column, Hempel, 200 mm, 2 ST 19/26 (usable also as chromatographic column)	13.103
1 Test tube with glass rings, Raschig, 4 x 4 mm	13.104
1 Fractionating column, Vigreux, 300 mm, 2 ST 19/26	13.105
1 Receiver tube, with serrated hose connector and screw-thread, GL 18/8	13.106
2 Drying tubes, ST 14/23	13.107
1 Screw-thread, with cone ST 19/26, GL 18/8	13.108
5 Clips for joints, ST 14/23	13.109
3 Clips for joints, ST 19/26	13.110

ST-Combi-Box „Semi-Mikro“ 14,
made of borosilicate glass, packed in
cardboard-box

*Kits d'expérimentation "Combi-Box" pour
différents montages de distillation / réaction,
Type , en verre borosilicaté, livré dans une boîte en
carton*

Type	Order No.
Type	N° de code
Complete/Complet	14.000
Spare parts / Pièces de rechange	
1 Flask, pear shaped, 100 ml, ST 19/26	14.101
1 Flask, pear shaped, 100 ml, center neck ST 19/26, side neck angled with screw-thread GL 18/8	14.102
1 Splash head, bent, with ST 19/26 - 14/23	14.103
1 Bent 105°, 2 ST 14/23	14.104
1 Vacuum stopcock, bore of plug 4 mm, tube outer Ø 8 mm	14.105
1 Delivery adapter, 2 ST 14/23 - GL 18/8	14.106
1 Condenser, Graham, 160 mm, 2 ST 14/23	14.107
1 Stirrer motor, with cable and plug, 220 V (complete with rod and stirrer paddle)	14.108
4 Clips for joints, ST 14/23	14.109
4 Clips for joints, ST 19/26	14.110

ST-Combi-Box „Semi-Mikro“ 15,
made of borosilicate glass, packed in
cardboard-box

*Kits d'expérimentation "Combi-Box" pour
différents montages de distillation / réaction,
Type semi-micro 15, en verre borosilicaté, livré
dans une boîte en carton*

Type	Order No.
Type	N° de code
Complete/Complet	15.000
Spare parts / Pièces de rechange	
1 U-tube, 2 ST 14/23	15.101
1 Funnel, Ø 50 mm, made of polypropylene	15.102
2 Suction tubes, bent, ST 14/23	15.103
2 Test tubes, 17 x 130 mm, with hollow stoppers ST 14/23	15.104
1 Extraxtor, acc. to Antlinger, ST 19/26 - 29/32	15.105
1 Extraxtor, insert for solid materials, ST 29/32 - 14/23	15.106
1 Extraxtor, using lighter solvents, ST 29/32 - 14/23	15.107
1 Wash bottle, 100 ml, made of polyethylene	15.108
1 Erlenmeyer flask, 100 ml, with hollow stopper ST 19/26	15.109
1 Filter pump, with built-in safety valve, made of polypropylene	15.110
2 Gaskets, silicone rubber, with PTFE washers, 16 x 6, GL 18/8	15.111
4 Clips for joints, ST 14/23	15.112
4 Clips for joints, ST 19/26	15.113
2 Clips for joints, ST 29/32	15.114

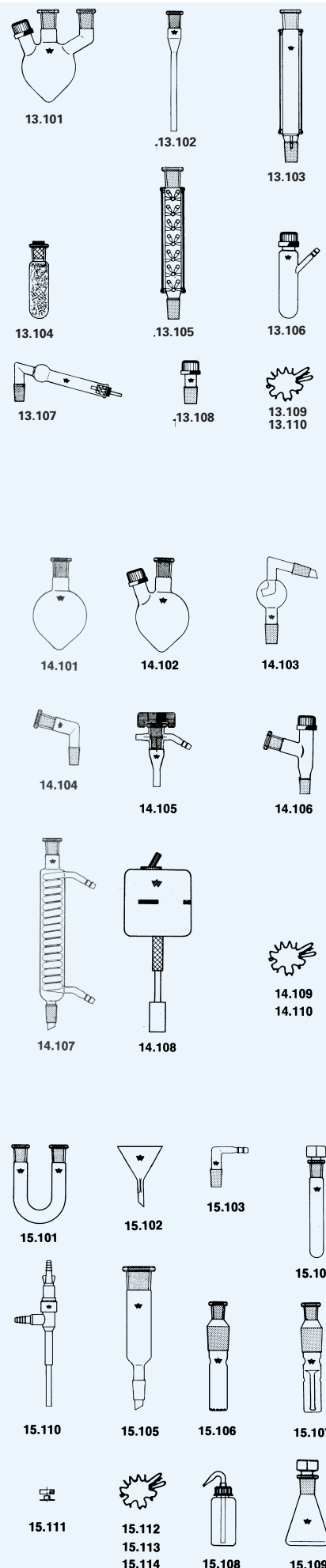

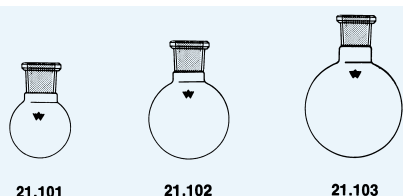

21.101 21.102 21.103

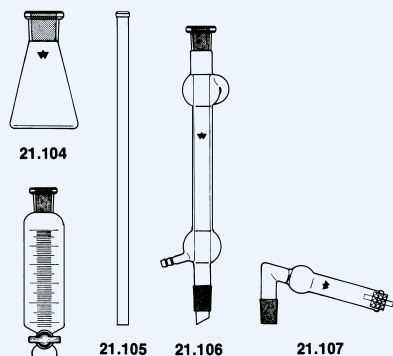

21.104 21.105 21.106 21.107

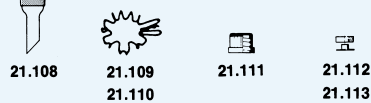

21.108 21.109 21.110 21.111 21.112 21.113 21.114



21.115 21.116 21.117



21.118 21.119 21.120

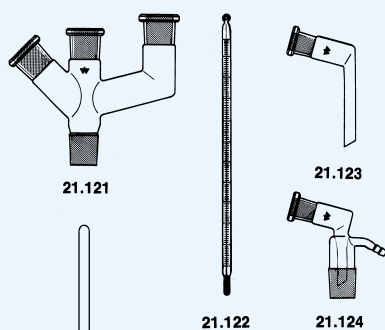

21.121 21.122 21.123 21.124

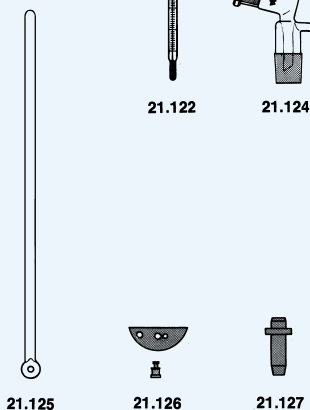

21.125 21.126 21.127

ST-Combi-Box „Makro“ 21,
made of borosilicate glass, packed in
cardboard-box

*Kits d'expérimentation "Combi-Box" pour
différents montages de distillation / réaction,
Type semi-micro 21, en verre borosilicaté, livré
dans une boîte en carton*

Type	Order No.
Type	N° de code
Complete/Complet	21.000
Spare parts / Pièces de rechange	
1 Flask, round bottom, 100 ml, ST 29/32	21.101
1 Flask, round bottom, 250 ml, ST 29/32	21.102
1 Flask, round bottom, 500 ml, ST 29/32	21.103
1 Erlenmeyer flask, 200 ml, ST 29/32	21.104
2 Air leak tubes, outer Ø 8 mm	21.105
1 Condenser, Liebig, 200 mm, wit 2 ST 19/26	21.106
1 Drying tube, ST 19/26	21.107
1 Dropping funnel, cylindrical, graduated 100 ml, ST 29/32 - 19/26	21.108
6 Clips for joints, ST 19/26	21.109
10 Clips for joints, ST 29/32	21.110
1 Screw cap, top closed, GL 18	21.111
10 Gaskets, silicone rubber, with PTFE washers, 16 x 6, GL 18	21.112
10 Gaskets, silicone rubber, with PTFE washers, 16 x 8, GL 25	21.113
10 Gaskets, silicone rubber, with PTFE washers, 22 x 8, GL 25	21.114
1 Hollow-stopper, ST 19/26	21.115
1 Hollow-stopper, ST 29/32	21.116
1 Reduction adapter, ST 29/32 - 19/26	21.117
1 Screw-thread with cone, ST 29/32 - GL 25/8	21.118
1 Delivery adapter, ST 29/32, GL 18/6, ST 19/26	21.119
1 Splash head, bent, ST 29/32 - 19/26	21.120
1 Multiple adapter, 3 necks, 4 ST 29/32	21.121
1 Thermometer, solid stem, - 10 to + 250°C : 1 °C	21.122
1 Delivery adapter, bent, ST 19/26	21.123
1 Receiver adapter, bent with vacuum connection and drip tip, ST 19/26 - 29/32	21.124
1 Stirrer shaft, outer Ø 7-8 mm suitable for usse PTFE-stirring blade with PTFE toggle	21.125
1 PTFE-stirrer blade, 50 x 24 mm	21.126
1 Insert, made of polypropylene, inner Ø 8mm for stirrer shaft, with rubber tubing and gasket, silicone rubber, PTFE washers 22 x 12, GL 25	21.127



ST-Combi-Box „Makro“ 22,
made of borosilicate glass, packed in
cardboard-box

*Kits d'expérimentation "Combi-Box" pour
différents montages de distillation / réaction,
Type semi-micro 22, en verre borosilicaté, livré
dans une boîte en carton*

Type	Order No.
Type	N° de code
Complete/Complet	22.000
Spare parts / Pièces de rechange	
1 Flask, round bottom, 1000 ml, ST 29/32	22.101
1 Flask, with 2 side necks, 1000 ml, center neck ST 29/32 2 side necks angled with screw-thread GL 18/6 - GL 18/8	22.102
2 Air leak tubes, outer Ø 8 mm	22.103
1 Thermometer, solid stem, - 10 to + 250°C : 1 °C	22.104
1 Intermediate receiver, Anschütz-Thiele, oblique adapter, ungraduated, ST 19/26 - 29/32	22.105
2 Clips for joints, ST 19/26	22.108
2 Clips for joints, ST 29/32	22.109
1 Fractionating column, Hempel, 300 mm, 2 ST 29/32	22.110
1 Fractionating column, Vigreux, 400 mm, 2 ST 29/32	22.111
1 Delivery adapter, straight, with suction tube, 2 ST 29/32	22.112
1 Bottle, 250 ml, 2 ST 29/32	22.114
1 Gas washing head, ST 29/32	22.115

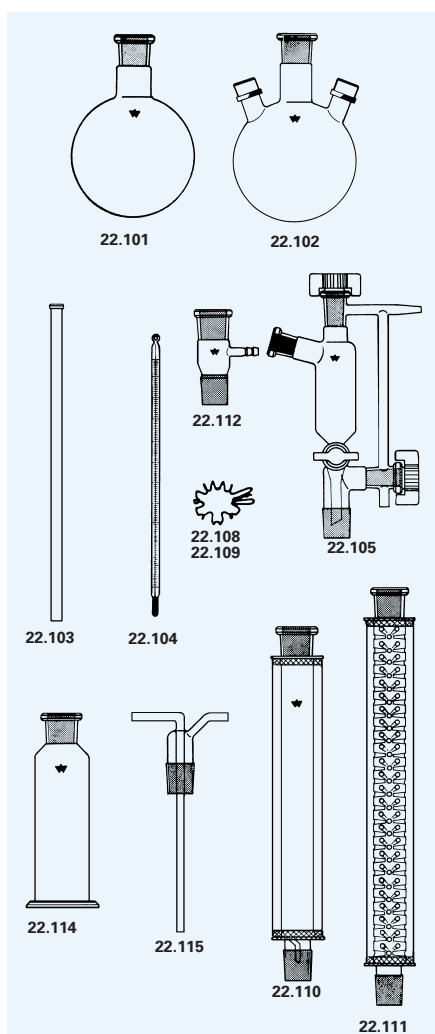

ST-Combi-Box „Makro“ 23,
made of borosilicate glass, packed in
cardboard-box

*Kits d'expérimentation "Combi-Box" pour
différents montages de distillation / réaction,
Type semi-micro 23, en verre borosilicaté, livré
dans une boîte en carton*

Type	Order No.
Type	N° de code
Complete/Complet	23.000
Spare parts / Pièces de rechange	
1 Reduction adapter, ST 45/40 - 29/32	23.101
1 Distilling link, 2 ST 29/32	23.102
1 Receiver adapter, straight, with vacuum connection and drip tip, 2 ST 29/32	23.103
1 Jacketed coil condenser, 250 mm, 2 ST 29/32	23.104
1 Measuring tube with ST stopcock, graduated, 10 ml : 0.1 ml, ST 29/32	23.105
1 Distributing tube, 2 ST 29/32	23.106
1 Extractor, acc. to Soxhlet, ST 29/32, ST 45/40 (for extraction thimbles 94 x 33 mm)	23.107
2 Clips for joints, ST 29/32	23.108
1 Clips for joints, ST 45/40	23.109

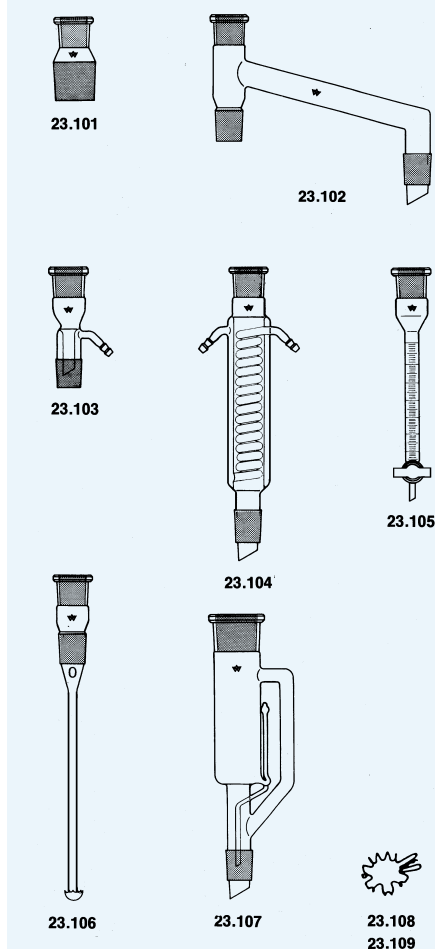

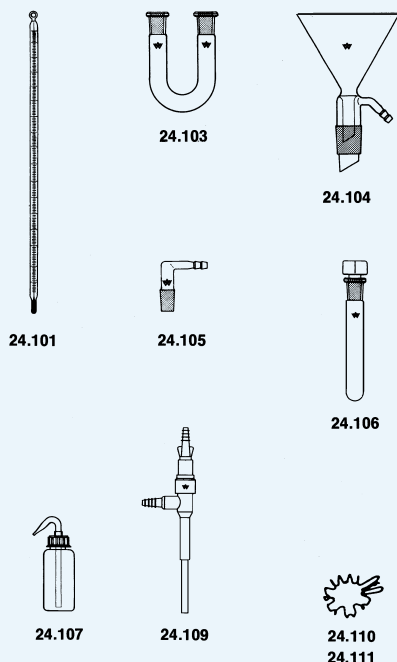

ST-Combi-Box „Makro“ 24,
made of borosilicate glass, packed in
cardboard-box

*Kits d'expérimentation "Combi-Box" pour
différents montages de distillation / réaction,
Type semi-micro 24, en verre borosilicaté, livré
dans une boîte en carton*

Type	Order No.
<i>Type</i>	<i>N° de code</i>
Complete/Complet	24.000
Spare parts / Pièces de rechange	
1 Thermometer, solid stem, - 10 to + 360 °C : 1 °C	24.101
1 U-tube, ST 14/23	24.103
1 Funnel with ST 29/32, Ø 60 mm, with vacuum connection and drip tip	24.104
2 Suction tubes, bent, ST 14/23	24.105
2 Test tubes, 17 x 130 mm, with hollow stopper, ST 14/23	24.106
1 Wash bottle, 100 ml, made of polyethylene	24.107
1 Filter pump with built-in valve, made of polypropylene	24.109
3 Clips for joints, ST 14/23	23.110
2 Clips for joints, ST 29/32	24.111

SVS-Combi-Box *Coffrets SVS d'expérimentation*



The present omnibus volume which contains approximately 120 experiments was created by practical men for the practice. The following points are characteristic to this volume:

- Didactically selected and exhaustively described experiments for the teachers.
- With didactic remarks.
- With formulated aims of learning.
- Indication of the results of the tasks in the text for the teachers only.
- Closely coupled with own experiments for the pupil.
- With observation and transfer tasks for the pupil.

Textbook for the experimental chemistry instruction – complete card index of experiments, as well as corresponding work sheet for pupils per experiment.

Experiment with the SVS-combi-box, by Prof. Dr. E. Höfling, Prof. Dr. H. Menrad, Stud.-Dir. W. Obermeyer.

Handbook for the chemistry instruction - only available in German language

Livre pour l'instruction de la chimie - seulement en langue allemande

Cet omnibus contient env. 120 expériences qui sont décrites pour des buts didactiques et en relation avec les kits SVS-Combi-Box proposés aux pages suivantes.

	Order No.
	<i>N° de code</i>
Complete/Complet	8.100.000

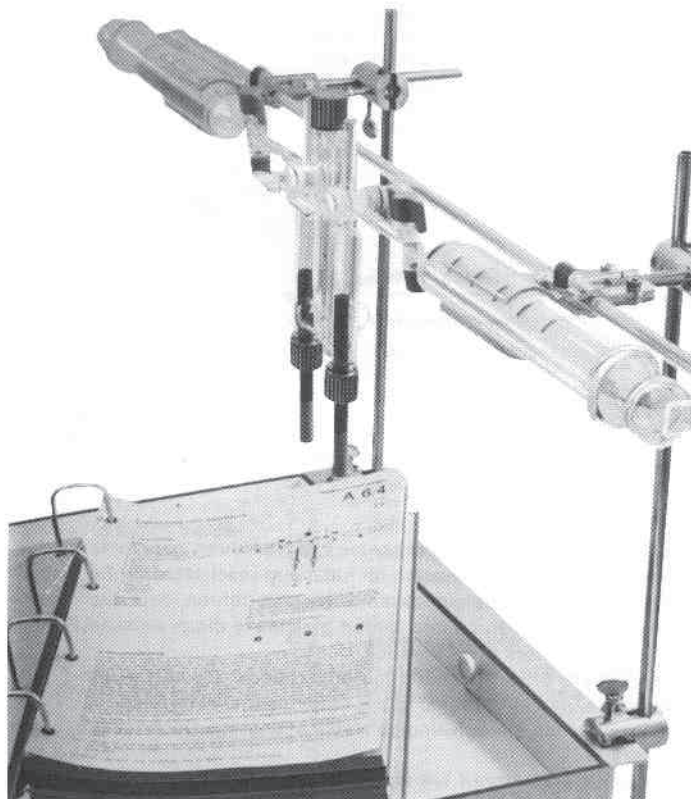
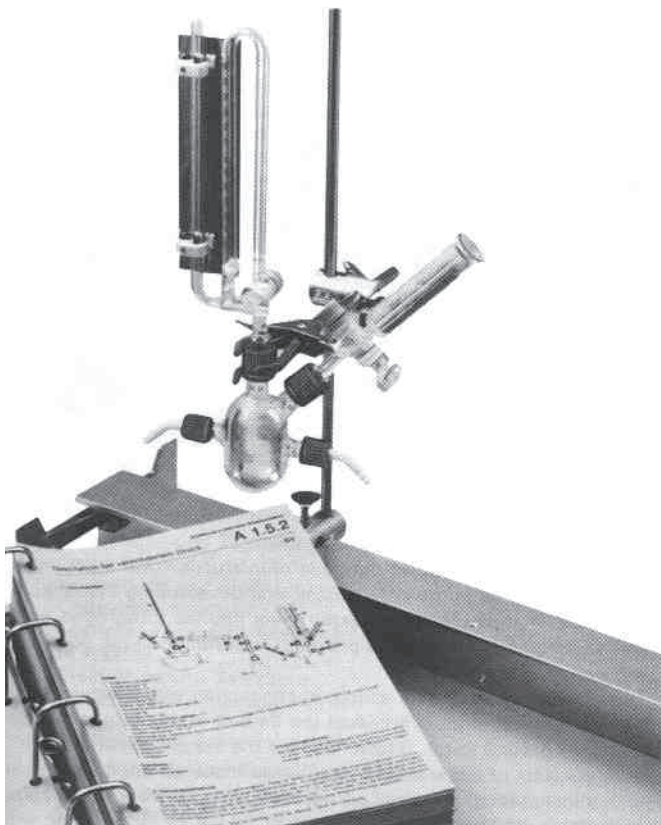
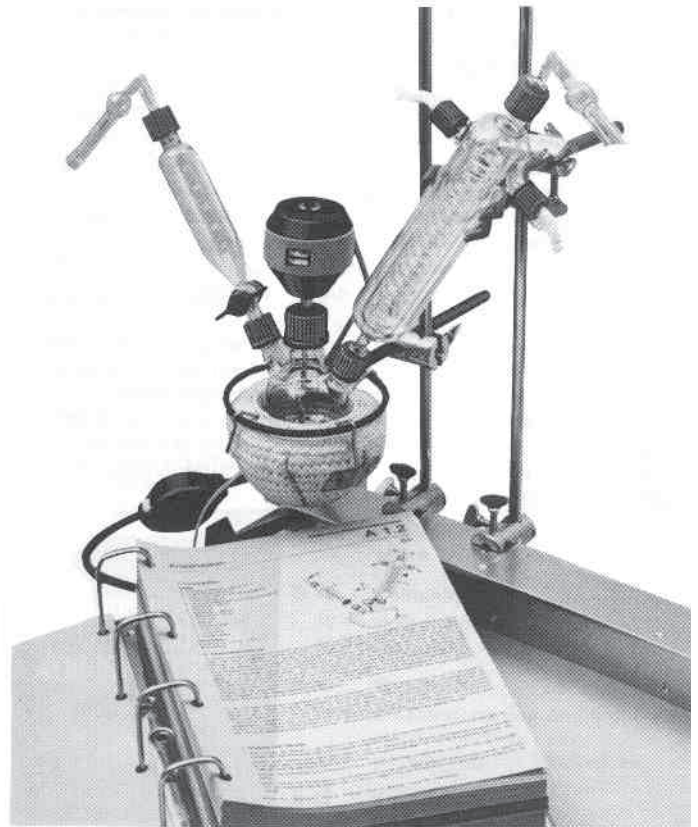
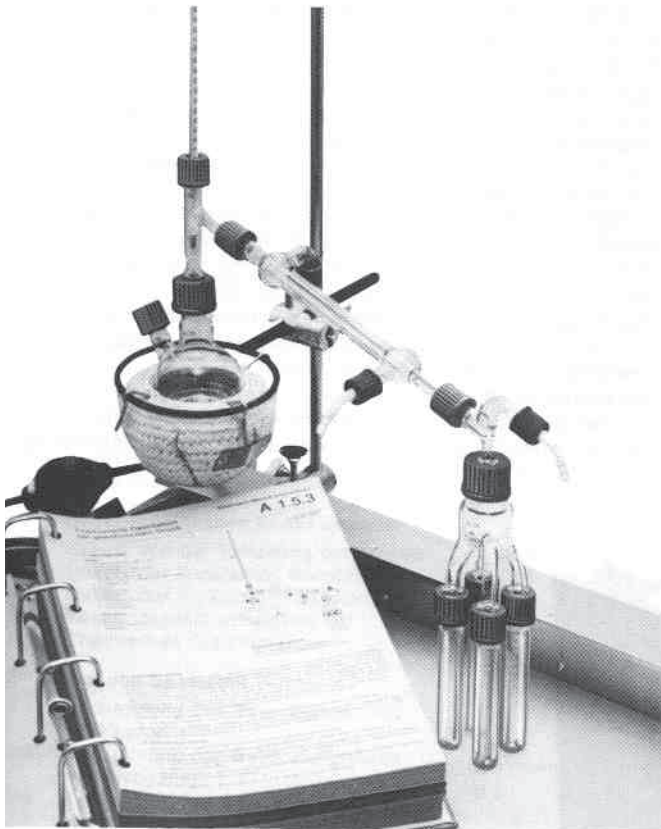



Index.

A General and inorganic chemistry/*Chimie générale et inorganique*

Section	Tests	Construction kit
A 1 Introduction into chemical working methods		
<i>Introduction dans les méthodes des travaux chimiques</i>		
1.1	Sedimenting and decanting	1
1.2	Crystallizing	4
1.3	Drying	4
1.4	Filtration	
	1.4.1 Filtration under normal pressure	1
	1.4.2 Filtration under reduced pressure	2
1.5	Distillation	
	1.5.1 Distillation under normal pressure	1
	1.5.2 Distillation under reduced pressure	5
	1.5.3 Fractionated distillation under normal pressure	2
	1.5.4 Fractionated distillation under reduced pressure	4
	1.5.5 Fractionated rectification	2
1.6	Sublimation	2
1.7	Separation with separating funnel	2
1.8	Extraction	
	1.8.1 Shaking out	2
	1.8.2 Extraction acc. to Soxhlet	4
1.9	Heating on the reflux	3
1.10	Absorption	3
1.11	Determination of boiling-point	4
A 2 Laws in chemistry/<i>Les lois dans la chimie</i>		
2.1	Law of the conservation of mass	1
2.2	Law of the constant proportions	1
2.3	Law of the multiple proportions	1
2.4	Reaction velocity	3
2.5	Chemical equilibrium	3
A 3 Air and oxygen/<i>Air et oxygène</i>		
3.1	Determination of the percentage of oxygen with copper	3
3.2	Determination of the percentage of oxygen with pyrogallol	3
3.3	Detection of carbon dioxide in the air	2
3.4	Production and properties of oxygen	1
3.5	Reactions in pure oxygen	3
A 4 Water and hydrogen/<i>Eau et hydrogène</i>		
4.1	Analysis of water with magnesium	1
4.2.1	Electrolysis of water with simple experimental arrangement	3
4.2.2	Electrolysis of water	3
4.3	Production and properties of hydrogen	3
4.4	Combustion of hydrogen	2
A 5 Metals/<i>Les Métaux</i>		
5.1.1	Reduction of ferric oxide with hydrogen	1
5.1.2	Reduction of ferric oxide with carbon monoxide	3
5.2.1	From mercuric oxide to mercury	1
5.2.2	Analysis of silver oxide	2
5.3	Reaction of metals with acids	1
5.4	Corrosion of iron	2
A 6 Halogens and compounds of halogen		
<i>Les Halogènes et composés halogénés</i>		
6.1	Production and properties of chlorine	3
6.2	Production and properties of chlorhydric acid gas	4
6.3	Solubity of chlorhydric acid gas in water	3
6.4	Electrolysis of hydrochloric acid	3
6.5	Reaction of chlorine with sodium	1
A 7 Sulphur and sulphur compounds		
<i>Le Soufre et composés sulfurés</i>		
7.1	From sulphur to sulphurous acid	2
7.2	Roasting process	2
7.3	Production and properties of sulphur dioxide	1
7.4	Contact process	1
7.5	Production and properties of hydrogen sulphide	1
7.6	Reaction of hydrogen sulphide with heavy metal ions	2

A General and inorganic chemistry/*Chimie générale et inorganique*

Section	Tests	Construction kit
A 8 Nitrogen, phosphorous and their compounds		
<i>L'Azote, le phosphore et leurs composés</i>		
8.1	Synthesis of ammonia acc. to Haber-Bosch	2
8.2	Production of ammonia out of ammonium salts	1
8.3	Solubility of ammonia in water	3
8.4	Quantitative determination of nitrogen in ammonium salts	4
8.5	Production of nitric acid out of nitrates	4
8.6	Combustion of ammonia acc. to Ostwald	4
8.7	Production and properties of nitrogen dioxide	1
8.8	Detection of white phosphorous acc. to Mitscherlich	1
A 9 Carbon and its compounds/<i>Le Carbone et ses composés</i>		
9.1	Production and properties of carbon dioxide	1
9.2	Carbon dioxide out of magnesium carbonate	1
9.3	Absorption of benzene and bromine on activated carbon	3
A 10 Protection of environment/<i>La protection de l'environnement</i>		
10.1	Detection of sulphur dioxide, during the combustion of fuel oil	2
10.2	Effect of sulphur dioxide on stones and metallic material	3
10.3	Washing out of sulphur dioxide with a calcium carbonate solution	2
10.4	Cleansing of oil-contaminated water	2
10.5	Combustion or decomposition of polyvinylchloride (PVC) respectively	2



B. Organic chemistry. / Chimie organique

Section	Tests	Construction kit
B 1 Aliphatic hydrocarbons/Hydrocarbures aliphatiques		
1.1	Detection of carbon and hydrogen in gaseous and liquid hydrocarbons	2
1.2	Detection of carbon and hydrogen in solid hydrocarbons	1,4
	Production and properties of methane	1,3
	1.3.1 out of aluminium carbide	1
	1.3.2 out of sodium acetate and sodium hydroxide	1
1.4	Fractionated distillation of petroleum	2
1.5	Production and properties of ethene	1
1.6	Production and properties of ethine	2
1.7	Formation of acetylide	2
1.8	Catalytic cracking and paraffin oil	2
B 2 Halogen alkanes/Les Halogènes alcanès		
2.1	Bromizing of hexane	4
2.2	Production of tri-iodine-methane (iodoform)	4
B 3 Alkanols (Alcohols)/Les alcools		
3.1	Production of ethanol through fermentation of glucose	1
3.2	Reaction of ethanol with sodium (formation of alcoholate)	1
3.3	Alcohol test reaction	2
B 4 Alkanals (Aldehydes)/Les aldehydes		
4.1	Production of methanol out of methanol	2
4.2	Production of ethanol through dehydrogenation of ethanol	2
4.3	Addition of ammonia on ethanol	3
4.4	Reducing effect of the alkanals	2
4.5	Condensation reactions of the alkanals (aldehydes)	2
B 5 Alkanones (Ketones)/Les acétones		
5.1	Production of propanone (acetone)	2
5.2	Propanone as solvent	2
B 6 Alkane acids (Carbonic acids)/Les acides carboniques		
6.1	Production and properties of formic acid	1
6.2	Production of acetic acid	2
	6.2.1 out of ethanol	2
	6.2.2 out of sodium acetate	2
6.3	Comparison of methane acid and ethane acid with regard to the reactivity with metals	4

B. Organic chemistry. / Chimie organique

Section	Tests	Construction kit
B 7 Ester/Les éthers		
7.1	Production of ester	
	7.1.1 Production of acetic acid ethyl ester	2
	7.1.2 Production of boric acid trimethyl ester	1
7.2	Hydrolysis of acetic acid ethyl ester	4
7.3	Extraction of oil out of peanut kernels	4
7.4	Hydrolysis of fat	4
B 8 Ether/Les éthers		
8.1	Production of diethylether	1
8.2	Properties of diethylether	4
B 9 Benzene and derivatives/Le Benzène et les dérivés		
9.1	Bromizing of benzene	2
9.2	Nitration of benzene	2
9.3	Production of aniline	3
9.4	Production of bromine toluol	4
9.5	Production of benzyl bromide	4
9.6	Production of benzoic acid	2
9.7	Water vapour volatility of benzoic acid	1
B 10 Carbohydrates/Les carbohydrates		
10.1	Hydrolysis of starch	2
10.2	Hydrolysis of cellulose	2
B 11 Dyes/Les colorants		
11.1	Di-acotation of aniline and coupling reactions	3
11.2	Production of fluoresceine	1
B 12 Plastics/Les plastiques		
12.1	Vacuum deep-drawing technique	1
12.2	Polymerization of acrylic acid	1
12.3	Polymerization of acryl nitrile	4
12.4	Production of a polyacryl nitrile fibre	3
12.5	Depolymerization	4
12.6	Production and hardening of a resol	2

C. Special fields. / Secteurs spéciaux

Section	Tests	Construction kit
C 1 Chromatography/La chromatographie		
1.1	Chromatographic separation of chlorophylls	
	1.1.1 with aluminium oxide, calcium-carbonate and icing sugar	2
	1.1.2 with siliceous gel	2
1.2	Chromatographic separation of synthetic colourants	2
C 2 Diffusion und osmosis/La diffusion et l'osmose		
2.1	Diffusion of chlorhydric acid gas and ammonia	3
2.2	Osmosis	3
C 3 Exchange of ions/L'échangeur d'ions		
3.1	Exchange of cations	2
3.2	Exchange of anions	2
3.3	Water softener	2



SVS-Combi Box, Set 1,
made of borosilicate glass, packed in foam
stuff beds and cardboard box

Coffret d'expérimentation SVS-Combi Box, Kit 1,
en verre borosilicaté, livré dans une boîte en
carton

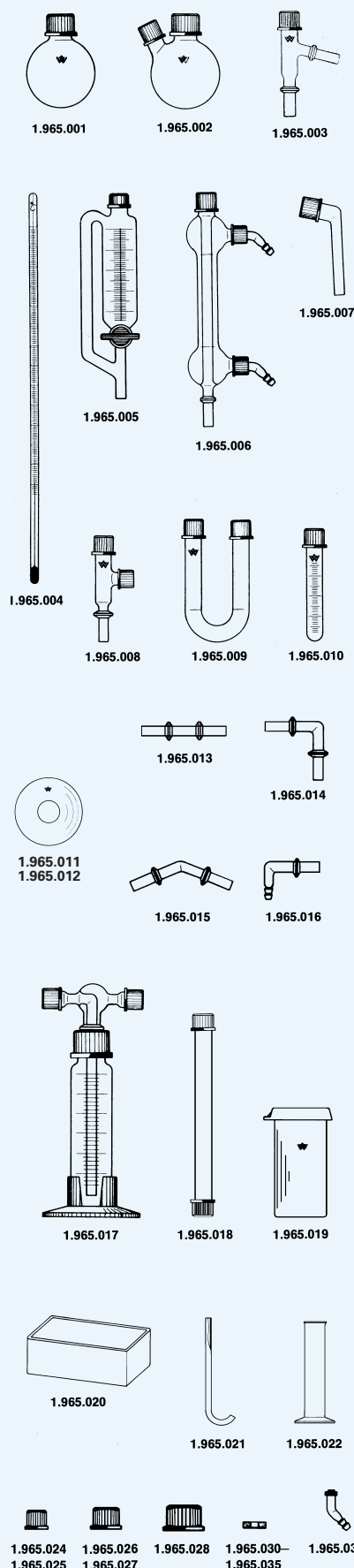

Type	Order No.
Type	N° de code
Complete/Complet	1.965.000
Spare parts / Pièces de rechange	
1 Flask, round bottom, 100 ml, with GL 25/12	1.965.001
2 Flask, 100 ml, center neck GL 25/12, side neck, angled GL 18/10	1.965.002
1 Recovery head, 1 FA 12, 1 FA 10, 1 GL 18/6	1.965.003
1 Thermometer, solid stem, range - 10 to + 250 °C : 1 °C	1.965.004
1 Dropping funnel, with pressure equalizing, cylindrical, graduated, with ST stopcock, 50 ml, GL 18	1.965.005
1 Liebig condenser, 160 mm, 1 GL 18/10, 1 FA 10, 2 GL 14/6 with 2 hose connection made of polypropylene	1.965.006
1 Delivery adapter inlet tube, bent, 1 GL 18/10	1.965.007
1 Adapter, straight, with side tube, 1 GL 18/10, 1 FA 10, 1 GL 14/6	1.965.008
1 U-tube, 2 GL 18/10	1.965.009
2 Test tubes, graduated, 10 ml, 1 GL 18/10	1.965.010
2 Isoplan-safety discs, 19 mm bore, (resistant up to 750 °C)	1.965.011
2 Isoplan-safety discs, 25 mm bore, (resistant up to 750 °C)	1.965.012
2 Connection tubes, straight, 2 FA 10	1.965.013
1 Connection tube, 90° bent, 2 FA 10	1.965.014
1 Connection tube, 120° bent, 2 FA 10	1.965.015
1 Connection tube, 90° bent, with hose connection, 1 FA 10	1.965.016
2 Wash bottles, graduated, 100 ml, with plastic base	1.965.017
1 GL 32/18,, with head 2 GL 18/10	1.965.018
1 Reaction tube, 2 GL 25/10	1.965.019
1 Container, filled with 40 boiling balls	1.965.020
1 Pneumatic tank, made of SAN, 340 x 230 x 94 mm with cover	1.965.021
1 Gas outlet tube, bent	1.965.022
1 Jar with ground cover 200 x 40 mm	1.965.023
2 Screw caps, top with hole, GL 14	1.965.024
6 Screw caps, top with hole, GL 18	1.965.025
3 Screw caps, top with hole, GL 25	1.965.026
2 Screw caps, top with hole, GL 32	1.965.027
1 Screw cap, top closed, GL 18, with PTFE washer	1.965.028
1 Gasket, silicone rubber, with PTFE washer 12 x 6 for GL 14, FA 6	1.965.030
1 Gasket, silicone rubber, with PTFE washer 16 x 6 for GL 18, FA 6	1.965.031
6 Gaskets, silicone rubber, with PTFE washer 16 x 10 for GL 18, FA 10	1.965.032
2 Gaskets, silicone rubber, with PTFE washer 22 x 10 for GL 25, FA 10	1.965.033
2 Gaskets, silicone rubber, with PTFE washer 22 x 12 for GL 25, FA 12	1.965.034
2 Gaskets, silicone rubber, with PTFE washer 29 x 18 for GL 32, FA 18	1.965.035
2 Hose connections, bent, GL 14, made of polypropylene	1.965.036



SVS-Combi Box, Set 2,

made of borosilicate glass, packed in foam stuff beds and cardboard box

Coffret d'expérimentation SVS-Combi Box, Kit 2, en verre borosilicaté, livré dans une boîte en carton

Type	Order No.
Type	N° de code
Complete / Complet	1.967.000
Spare parts / Pièces de rechange	
1 Flask, round bottom, 100 ml, with GL 25/12	1.967.001
1 Flask, 100 ml, center neck GL 25/12, two side neck, angled, GL 18/6, GL 18/10	1.967.002
1 Claisen head, 1 FA 12, 1 FA 10, 1 GL 18/10, 1 GL 18/6	1.967.003
1 Fractionating column, Hempel, 200 mm, 1 FA 12, 1 GL 25/12	1.967.004
1 Container filled with raschig rings 3 x 3 mm	1.967.005
1 Dropping funnel, cylindrical, graduated, with ST stopcock, 50 ml, GL 18/10	1.967.006
1 Jacketed coil condenser, 200 mm, 1 GL 18/10, 1 FA 10, 2 GL 14/6 with 2 hose connection made of polypropylene	1.967.007
1 Delivery adapter inlet tube, straight, 1 GL 18/10	1.967.008
1 Distilling receiver, Bredt, 1 GL 18/10, 1 GL 25/12, 1 GL 14/6 with 4 FA 10	1.967.009
1 U-tube, 2 GL 18/10	1.967.010
4 Test tubes, graduated, 10 ml, 1 GL 18/10	1.967.011
1 Reaction tube, small, 2 GL 18/10	1.967.012
1 Connection tubes, straight, 2 FA 10	1.967.013
1 Connection tube, 90° bent, 2 FA 10	1.967.014
1 Connection tube, 90° bent, with hose connection, 1 FA 10	1.967.015
1 Gas inlet tube, 1 GL 18/6	1.967.016
1 Filter funnel, 50 ml, porosity P2, 1 FA 10	1.967.017
1 Funnel, glass, 70 mm Ø	1.967.018
1 Ceramic-plate 135 x135 mm	1.967.019
2 Screw caps, top with hole, GL 14	1.967.020
8 Screw caps, top with hole, GL 18	1.967.021
2 Screw caps, top with hole, GL 25	1.967.022
1 Gasket, silicone rubber, with PTFE washer 12 x 6 for GL 14, FA 6	1.967.023
1 Gasket, silicone rubber, with PTFE washer 16 x 6 for GL 18, FA 6	1.967.024
8 Gaskets, silicone rubber, with PTFE washer 16 x 10 for GL 18, FA 10	1.967.025
2 Gaskets, silicone rubber, with PTFE washer 22 x 12 for GL 25, FA 12	1.967.026
2 Hose connections, bent, GL 14, made of polypropylene	1.967.027



1.967.001



1.967.002

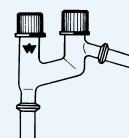

1.967.003

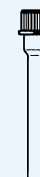

1.967.008



1.967.009



1.967.005

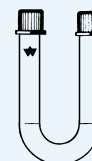

1.967.010

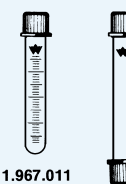

1.967.011

1.967.012



1.967.013



1.967.014



1.967.015



1.967.016



1.967.017



1.967.018



1.967.019

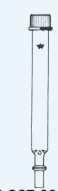

1.967.004



1.967.006

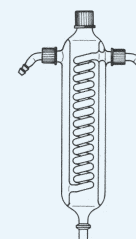

1.967.007



1.967.020

1.967.021
1.967.0221.967.023-
1.967.026

1.967.027

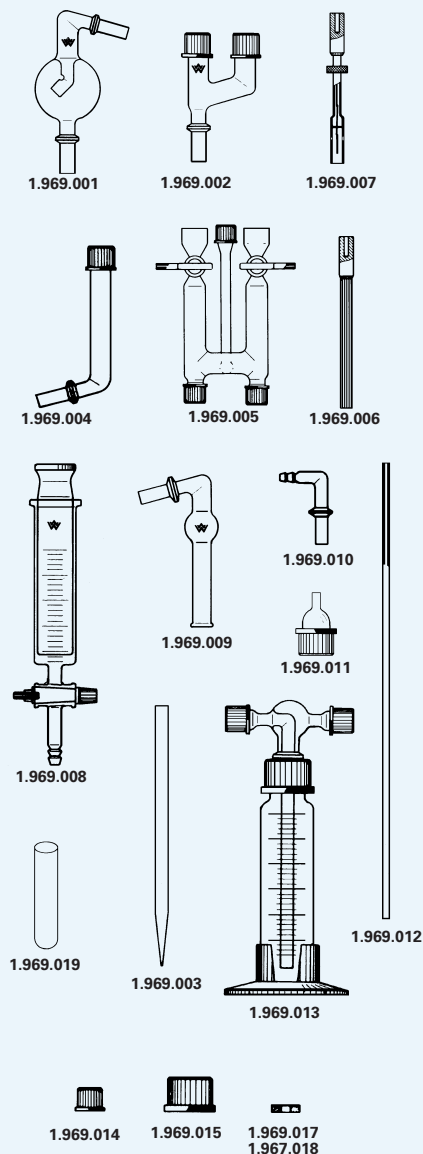

SVS-Combi Box, Set 3,
made of borosilicate glass, packed in foam
stuff beds and cardboard box

Coffret d'expérimentation SVS-Combi Box, Kit 3,
en verre borosilicaté, livré dans une boîte en
carton

Type	Order No.
<i>Type</i>	<i>N° de code</i>
Complete / Complet	1.969.000
Spare parts / Pièces de rechange	
1 Splash head, bent, 1 FA 12, 1 FA 10	1.969.001
1 Distilling head, 1 FA 12, 2 GL 18/10	1.969.002
1 Air leak tube, outer Ø 10 mm	1.969.003
1 Adapter, bent 105°, 1 GL 18/10, 1 FA 10	1.969.004
1 Electrolysis apparatus, 2 GL 18/10	1.969.005
2 Coal electrodes, outer Ø 10 mm	1.969.006
2 Nickel electrodes, outer Ø 10 mm	1.969.007
(On request we deliver platin electrodes against surcharge)	
2 Gas syringue with ST-stopcock, 100 ml	1.969.008
1 Drying tube, bent, 1 FA 10	1.969.009
1 Connection tube, 90° bent, with hose connection, 1 FA 10	1.969.010
1 Screw-thread with glass part of osmosis apparatus, 1 GL 32/18	1.969.011
1 Capillary tube, inner Ø 1 mm, length 500 mm	1.969.012
1 Wash bottle, graduated, 100 ml, with plastic base, 1 GL 32/18 with head 2 GL 18/10	1.969.013
4 Screw caps, top with hole, GL 18	1.969.014
1 Screw caps, top with hole, GL 32	1.969.015
4 Gaskets, silicone rubber, with PTFE washer 16 x 10 for GL 18, FA 10	1.969.017
1 Gaskets, silicone rubber, with PTFE washer 29 x 18 for GL 32, FA 18	1.969.018
1 Test tube, Fiolax-glass, 30 x 200 mm	1.969.019



SVS-Combi Box, Set 4,

made of borosilicate glass, packed in foam stuff beds and cardboard box

Coffret d'expérimentation SVS-Combi Box, Kit 4, en verre borosilicaté, livré dans une boîte en carton

Type	Order No.
Type	N° de code
Complete / Complet	1.971.000
Spare parts / Pièces de rechange	
1 Flask, 100 ml, center neck GL 25/12, side neck, angled GL 18/10	1.971.001
1 Thermometer, solid stem, range - 10 to + 360 °C : 1 °C	1.971.002
1 Air leak tube, outer Ø 10 mm	1.971.003
1 Gas inlet tube, 1 GL 14/6	1.971.004
1 Soxhlet extractor, 30 ml capacity for extraction thimbles, 90 x 19 mm, 1 GL 32/10, 1 FA 12	1.971.005
3 Extraction thimbles, for 30 ml extractor, 90 x 19 mm	1.971.006
1 Drying tube, straight, 1 GL 18/10, 1 FA 6	1.971.007
1 Drying tube, bent, 1 FA 10	1.971.008
1 Connection tube, bent 75°, 2 FA 10	1.971.009
1 Reaction tube, small, 2 GL 18/10	1.971.010
1 Vacuum receiver, 2 GL 18/10, 2 GL 14/6 with 2 hose connections, made of polypropylene	1.971.011
1 Manometer, mercury, with movable mirror glass scale, 1 FA 10	1.971.012
1 Tube with stopcock, filled with foam stuff, 1 FA 10	1.971.013
1 Filter pump, made of polypropylene with built-in valve and 2 hose connections	1.971.014
1 Stirrer motor, 220 V, with holding rod and stirring blade	1.971.015
1 Wash bottle, 100 ml, made of polyethylene	1.971.016
1 Funnel, outer Ø 70 mm, made of polyethylene	1.971.017
1 Beaker, low form, 600 ml, graduated	1.971.018
1 Beaker, tall form, 100 ml, graduated	1.971.019
2 Hose connection, bent, GL 14, made of polypropylene	1.971.020
2 Screw caps, top with hole, GL 14	1.971.021
4 Screw caps, top with hole, GL 18	1.971.022
1 Screw caps, top with hole, GL 25	1.971.023
1 Screw caps, top with hole, GL 32	1.971.024
2 Gaskets, silicone rubber, with PTFE washer 12 x 6 for GL 14, FA 6	1.971.025
4 Gaskets, silicone rubber, with PTFE washer 16 x 10 for GL 18, FA 10	1.971.026
1 Gaskets, silicone rubber, with PTFE washer 22 x 12 for GL 25, FA 12	1.971.027
1 Gaskets, silicone rubber, with PTFE washer 29 x 18 for GL 32, FA 18	1.971.028

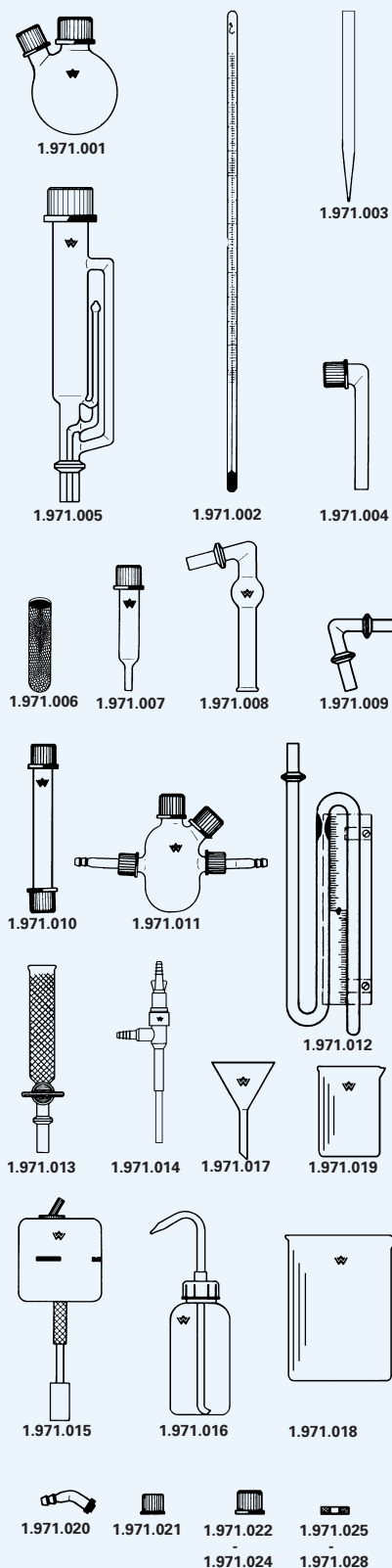



Drying tubes
Tubes de séchage

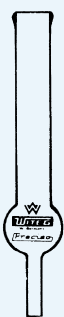

2.110.***

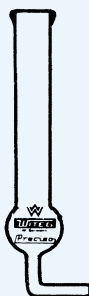

2.112.***

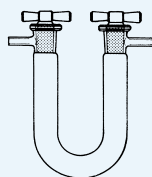

2.114.***

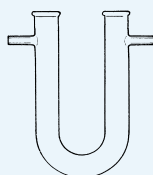

2.115.***



2.116.***

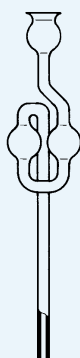

2.118.***

Drying tubes, with 1 bulb, straight, made of borosilicate glass

Tubes de séchage, droit à une ampoule, en verre borosilicaté

Length Longueur mm	inner Ø Ø int. mm	Order No. N° de code
100	13	2.110.100
125	13	2.110.125
150	13	2.110.150
200	18	2.110.200

Drying tubes, with 1 bulb, bent, made of borosilicate glass

Tubes de séchage, coudé à une ampoule, en verre borosilicaté

Length Longueur mm	inner Ø Ø int. mm	Order No. N° de code
100	13	2.112.100
125	13	2.112.125
150	13	2.112.150
200	18	2.112.200

Drying tubes, U-shaped, with hollow glass stoppers, made of borosilicate glass

Tubes de séchage, en U avec bouchon à rodage, en verre borosilicaté

Length Longueur mm	inner Ø Ø int. mm	ST Rodage	Order No. N° de code
80	9	10/19	2.114.080
100	13	12/21	2.114.100
125	16	14/23	2.114.125
150	18	19/26	2.114.150
250	18	19/26	2.114.250

Drying tubes, U-shaped, with side connections, made of borosilicate glass

Tubes de séchage, en U avec raccords sur les extrémités, en verre borosilicaté

Length Longueur mm	inner Ø Ø int. mm	Order No. N° de code
80	9	2.115.080
100	13	2.115.100
125	16	2.115.125
150	18	2.115.150
250	18	2.115.250

See also order No. 5.624.*** /

U-tubes, made of borosilicate glass

Tubes de séchage, en U simple en verre borosilicaté

Length Longueur mm	inner Ø Ø int. mm	Order No. N° de code
80	9	2.116.080
100	13	2.116.100
125	16	2.116.125
150	18	2.116.150
250	18	2.116.250

Thistle funnel, with bend and two bulbs, made of borosilicate glass

Entonnoir à 2 boules de Thistle, en verre borosilicaté

Height Hauteur mm	inner Ø Ø int. mm	Order No. N° de code
400	6	2.118.000



Chromatography
Chromatographie

Chromatography-columns, ST-stopcock, with solid plug and screw-thread retaining nut, with indentations above the stopcock for a wad of cotton, made of borosilicate glass

Colonnes de chromatographie, en verre borosilicaté avec robinet à clé en verre, version simple

Column inner Ø	Column capacity	Effective length	Bore of plug	Order No.
Ø int mm	Capacité ml	Longueur effective mm	Voie mm	N° de code
10	15	200	2.5	2.119.001
15	35	200	2.5	2.119.002
15	70	400	2.5	2.119.003
20	125	400	2.5	2.119.004
30	280	400	2.5	2.119.005
20	190	600	2.5	2.119.006
30	430	600	2.5	2.119.007
40	1000	800	2.5	2.119.008

Chromatography-columns, ST-PTFE-stopcock, with solid plug and screw-thread retaining nut, with indentations above the stopcock for a wad of cotton, made of borosilicate glass

Colonnes de chromatographie, en verre borosilicaté avec robinet à clé en téflon, version simple

Column inner Ø	Column capacity	Effective length	Bore of plug	Order No.
Ø int mm	Capacité ml	Longueur effective mm	Voie mm	N° de code
10	15	200	2.5	2.120.001
15	35	200	2.5	2.120.002
15	70	400	2.5	2.120.003
20	125	400	2.5	2.120.004
30	280	400	2.5	2.120.005
20	190	600	2.5	2.120.006
30	430	600	2.5	2.120.007
40	1000	800	2.5	2.120.008

Chromatography-columns, with PTFE needle valve stopcock, with indentations above the stopcock for a wad of cotton, made of borosilicate glass

Colonnes de chromatographie, en verre borosilicaté à vanne et clé en téflon, version simple

Column inner Ø	Column capacity	Effective length	Bore of plug	Order No.
Ø int mm	Capacité ml	Longueur effective mm	Voie mm	N° de code
10	15	200	2.5	2.121.001
15	35	200	2.5	2.121.002
15	70	400	2.5	2.121.003
20	125	400	2.5	2.121.004
30	280	400	2.5	2.121.005
20	190	600	2.5	2.121.006
30	430	600	2.5	2.121.007
40	1000	800	2.5	2.121.008

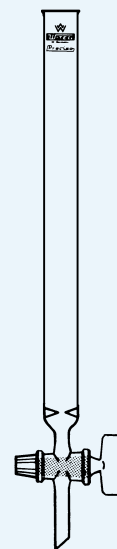

2.119.***

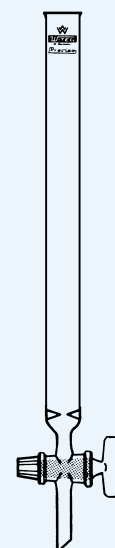

2.120.***

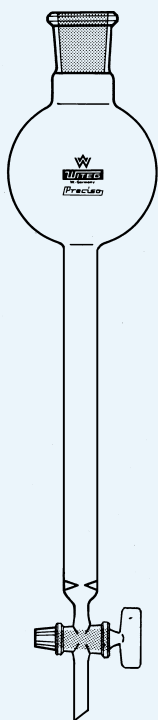

2.122.***

2.123.***

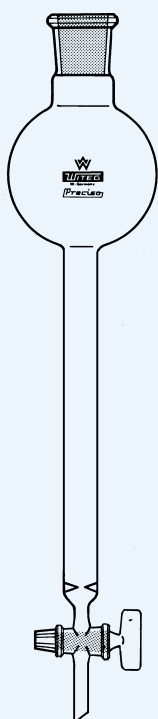

2.124.***

Chromatography-columns, ST-stopcock, with solid plug and screw-thread retaining nut, with indentations above the stopcock for a wad of cotton, with socket ST 29/32, made of borosilicate glass

Colonnes de chromatographie en verre borosilicaté avec réservoir à rodage 29/32 et robinet à clé en verre.

Column inner Ø	Column capacity	Effective length	Reservoir	Bore of plug	Order No.
Ø int	Capacité	Longueur	Réservoir	Voie	N° de code
mm	ml	mm	ml	mm	
10	15	200	250	2.5	2.122.001
15	35	200	250	2.5	2.122.002
20	65	200	250	2.5	2.122.003
20	125	400	250	2.5	2.122.004
30	280	400	500	2.5	2.122.005
20	190	600	250	2.5	2.122.006
40	750	600	1000	2.5	2.122.007
60	1150	600	2000	6.3	2.122.008
60	1550	800	2000	6.3	2.122.009
80	4500	1000	4000	6.3	2.122.010

Chromatography-columns, ST-PTFE-stopcock, with screw-thread retaining nut, with indentations above the stopcock for a wad of cotton, with socket ST 29/32, made of borosilicate glass

Colonnes de chromatographie en verre borosilicaté avec réservoir à rodage 29/32 et robinet à clé en téflon

Column inner Ø	Column capacity	Effective length	Reservoir	Bore of plug	Order No.
Ø int	Capacité	Longueur	Réservoir	Voie	N° de code
mm	ml	mm	ml	mm	
10	15	200	250	2.5	2.123.001
15	35	200	250	2.5	2.123.002
20	65	200	250	2.5	2.123.003
20	125	400	250	2.5	2.123.004
30	280	400	500	2.5	2.123.005
20	190	600	250	2.5	2.123.006
40	750	600	1000	2.5	2.123.007
60	1150	600	2000	6.3	2.123.008
60	1550	800	2000	6.3	2.123.009
80	4500	1000	4000	6.3	2.123.010

Chromatography-columns, with PTFE needle valve stopcock, with indentations above the stopcock for a wad of cotton, with socket ST 29/32, made of borosilicate glass

Colonnes de chromatographie en verre borosilicaté avec réservoir à rodage 29/32 et vanne à clé en téflon

Column inner Ø	Column capacity	Effective length	Reservoir	Bore of plug	Order No.
Ø int	Capacité	Longueur	Réservoir	Voie	N° de code
mm	ml	mm	ml	mm	
10	15	200	250	2.5	2.124.001
15	35	200	250	2.5	2.124.002
20	65	200	250	2.5	2.124.003
20	125	400	250	2.5	2.124.004
30	280	400	500	2.5	2.124.005
20	190	600	250	2.5	2.124.006
40	750	600	1000	2.5	2.124.007
60	1150	600	2000	6.3	2.124.008
60	1550	800	2000	6.3	2.124.009
80	4500	1000	4000	6.3	2.124.010

Chromatography-columns, ST-stopcock, with solid plug and screw-thread retaining nut, with indentations above the stopcock for a wad of cotton, made of borosilicate glass

Colonnes de chromatographie en verre borosilicaté avec col à rodage femelle et robinet à clé en verre

Column inner Ø	Column capacity	Effective length	Socket	Bore of plug	Order No.
Ø int	Capacité	Longueur	Cône femelle	Voie	N° de code
mm	ml	mm	ST	mm	
10	15	200	14/23	2.5	2.125.001
20	125	400	29/32	2.5	2.125.002
30	130	600	29/32	2.5	2.125.003
40	1000	800	29/32	2.5	2.125.004



Chromatography-columns,
ST-PTFE-stopcock, screw-thread retaining
nut, with indentations above the stopcock
for a wad of cotton, made of borosilicate
glass

*Colonnes de chromatographie
en verre borosilicaté avec col à rodage femelle et
robinet à clé en téflon*

Column inner Ø	Column capacity	Effective length	Socket	Bore of plug	Order No.
Ø int	Capacité	Longueur	Cône femelle	Voie	N° de code
mm	ml	mm	ST	mm	
10	15	200	14/23	2.5	2.126.001
20	125	400	29/32	2.5	2.126.002
30	130	600	29/32	2.5	2.126.003
40	1000	800	29/32	2.5	2.126.004

Chromatography-columns,
with PTFE needle valve stopcock, with
indentations above the stopcock for a wad
of cotton, made of borosilicate glass

*Colonnes de chromatographie
en verre borosilicaté avec col à rodage femelle et
vanne à clé en téflon*

Column inner Ø	Column capacity	Effective length	Socket	Bore of plug	Order No.
Ø int	Capacité	Longueur	Cône femelle	Voie	N° de code
mm	ml	mm	ST	mm	
10	15	200	14/23	2.5	2.127.001
20	125	400	29/32	2.5	2.127.002
30	130	600	29/32	2.5	2.127.003
40	1000	800	29/32	2.5	2.127.004

Chromatography-c-columns, with fused-in
sintered glass-disc P0 without ST-stopcock,
made of borosilicate glass

*Colonnes de chromatographie
en verre borosilicaté avec verre fritté à porosité 0,
sans robinet*

Column inner Ø	Column capacity	Effective length	Order No.
Ø int	Capacité	Longueur effective	N° de code
mm	ml	mm	
10	15	200	2.128.001
15	35	200	2.128.002
15	70	400	2.128.003
20	125	400	2.128.004
30	280	400	2.128.005
20	190	600	2.128.006
30	430	600	2.128.007
40	1000	800	2.128.008

Chromatography-columns, with fused-in
sintered glass-disc P0, ST-stopcock, with
solid plug and screw-thread retaining nut,
made of borosilicate glass

*Colonnes de chromatographie
en verre borosilicaté avec verre fritté à porosité 0
et robinet interchangeable en verre*

Column inner Ø	Column capacity	Effective length	Bore of plug	Order No.
Ø int	Capacité	Longueur effective	Voie	N° de code
mm	ml	mm	mm	
10	15	200	2.5	2.129.001
15	35	200	2.5	2.129.002
15	70	400	2.5	2.129.003
20	125	400	2.5	2.129.004
30	280	400	2.5	2.129.005
20	190	600	2.5	2.129.006
30	430	600	2.5	2.129.007
40	1000	800	2.5	2.129.008

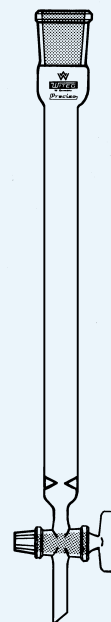

2.126.***
-
2.127.***

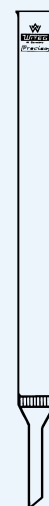

2.128.***

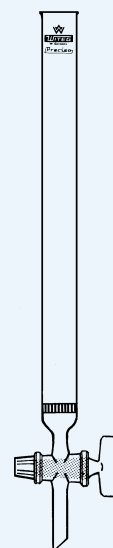

2.129.***

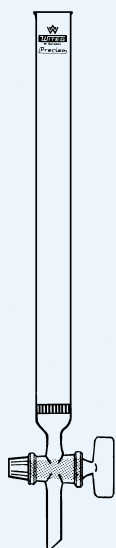

2.130.**

Chromatography-columns, with fused-in sintered glass-disc P0, ST-PTFE-stopcock, with screw-thread retaining nut, made of borosilicate glass

Colonnes de chromatographie en verre borosilicaté avec verre fritté à porosité 0 et robinet interchangeable à clé en téflon

Column inner Ø	Column capacity	Effective length	Bore of plug	Order No.
Ø int mm	Capacité ml	Longueur effective mm	Voie mm	N° de code
10	15	200	2.5	2.130.001
15	35	200	2.5	2.130.002
15	70	400	2.5	2.130.003
20	125	400	2.5	2.130.004
30	280	400	2.5	2.130.005
20	190	600	2.5	2.130.006
30	430	600	2.5	2.130.007
40	1000	800	2.5	2.130.008

Chromatography-columns, with fused-in sintered glass-disc P0, with PTFE needle valve stopcock, made of borosilicate glass

Colonnes de chromatographie en verre borosilicaté avec verre fritté à porosité 0 et vanne et clé en téflon

Column inner Ø	Column capacity	Effective length	Bore of plug	Order No.
Ø int mm	Capacité ml	Longueur effective mm	Voie mm	N° de code
10	15	200	2.5	2.131.001
15	35	200	2.5	2.131.002
15	70	400	2.5	2.131.003
20	125	400	2.5	2.131.004
30	280	400	2.5	2.131.005
20	190	600	2.5	2.131.006
30	430	600	2.5	2.131.007
40	1000	800	2.5	2.131.008

Chromatography-columns, with fused-in sintered glass-disc, P0, ST-stopcock, with solid plug and screw-thread retaining nut, made of borosilicate glass

Colonnes de chromatographie en verre borosilicaté avec verre fritté à porosité 0, col à rodage femelle et robinet interchangeable à clé en verre

Column inner Ø	Column capacity	Effective length	Socket	Bore of plug	Order No.
Ø int mm	Capacité ml	Longueur mm	Cône femelle ST	Voie mm	N° de code
10	8	100	14/23	2.5	2.132.001
15	18	100	14/23	2.5	2.132.002
10	15	200	14/23	2.5	2.132.003
15	35	200	14/23	2.5	2.132.004
20	60	200	29/32	2.5	2.132.005
10	23	300	14/23	2.5	2.132.006
15	50	300	14/23	2.5	2.132.007
20	90	300	29/32	2.5	2.132.008
15	70	400	14/23	2.5	2.132.009
20	125	400	29/32	2.5	2.132.010
30	280	400	29/32	2.5	2.132.011
20	190	600	29/32	2.5	2.132.012
30	430	600	29/32	2.5	2.132.013
40	1000	800	29/32	2.5	2.132.014



2.132.3**

Flash Chromatography Columns, made of borosilicate glass, consisting of column, reservoir and flow regulation valve with PTFE valve stopcock with Superfix safety device

Colonnes de chromatographie, en verre borosilicaté, consistant un réservoir avec vanne de regulation de debit à clé en téflon et dispositif de sécurité Superfix

Column Volume	Bore of valve	Reservoir Volume	Socket	Regulation bore	Order No.
Volume ml	Voie mm	Volume reservoir ml	Cône femelle ST	mm	N° de code
100	0-3	100	29/32	0-3	2.132.301
200	0-3	250	29/32	0-3	2.132.302
400	0-3	500	29/32	0-3	2.132.304
600	0-3	500	29/32	0-3	2.132.306
1000	0-3	1000	45/40	0-3	2.132.310
2000	0-3	2000	45/40	0-3	2.132.320



Chromatography-columns, with fused-in sintered glass-disc P0, ST-PTFE-stopcock, screw-thread retaining nut, made of borosilicate glass

Colonnes de chromatographie en verre borosilicaté avec verre fritté à porosité 0, col à rodage femelle et robinet interchangeable à clé en téflon

Column inner Ø	Column capacity	Effective length	Socket	Bore of plug	Order No.
Ø int mm	Capacité ml	Longueur mm	Cône femelle ST	Voie mm	N° de code
10	8	100	14/23	2.5	2.133.001
15	18	100	14/23	2.5	2.133.002
10	15	200	14/23	2.5	2.133.003
15	35	200	14/23	2.5	2.133.004
20	60	200	29/32	2.5	2.133.005
10	23	300	14/23	2.5	2.133.006
15	50	300	14/23	2.5	2.133.007
20	90	300	29/32	2.5	2.133.008
15	70	400	14/23	2.5	2.133.009
20	125	400	29/32	2.5	2.133.010
30	280	400	29/32	2.5	2.133.011
20	190	600	29/32	2.5	2.133.012
30	430	600	29/32	2.5	2.133.013
40	1000	800	29/32	2.5	2.133.014

Chromatography-columns, with fused-in sintered glass-disc P0, with PTFE needle valve stopcock, made of borosilicate glass

Colonnes de chromatographie en verre borosilicaté avec verre fritté à porosité 0, col à rodage femelle et vanne à clé en téflon

Column inner Ø	Column capacity	Effective length	Socket	Bore of plug	Order No.
Ø int mm	Capacité ml	Longueur mm	Cône femelle ST	Voie mm	N° de code
10	8	100	14/23	2.5	2.134.001
15	18	100	14/23	2.5	2.134.002
10	15	200	14/23	2.5	2.134.003
15	35	200	14/23	2.5	2.134.004
20	60	200	29/32	2.5	2.134.005
10	23	300	14/23	2.5	2.134.006
15	50	300	14/23	2.5	2.134.007
20	90	300	29/32	2.5	2.134.008
15	70	400	14/23	2.5	2.134.009
20	125	400	29/32	2.5	2.134.010
30	280	400	29/32	2.5	2.134.011
20	190	600	29/32	2.5	2.134.012
30	430	600	29/32	2.5	2.134.013
40	1000	800	29/32	2.5	2.134.014

Chromatography-columns, with fused-in sintered glass-disc P0, ST-stopcock, with solid plug and screw-thread retaining nut, with vacuum connection and drip tip, made of borosilicate glass

Colonnes de chromatographie en verre borosilicaté avec verre fritté à porosité 0, col à rodage femelle, robinet interchangeable à clé en verre et raccord à vis pour vide

Column inner Ø	Column capacity	Effective length	Socket	Bore of plug	Order No.
Ø int mm	Capacité ml	Longueur mm	Cône femelle ST	Voie mm	N° de code
10	8	100	14/23	2.5	2.135.001
15	18	100	14/23	2.5	2.135.002
10	15	200	14/23	2.5	2.135.003
15	35	200	14/23	2.5	2.135.004
20	60	200	29/32	2.5	2.135.005
30	80	200	29/32	2.5	2.135.006
10	23	300	14/23	2.5	2.135.007
15	50	300	14/23	2.5	2.135.008
20	90	300	29/32	2.5	2.135.009
15	70	400	14/23	2.5	2.135.010
20	125	400	29/32	2.5	2.135.011
30	280	400	29/32	2.5	2.135.012
20	190	600	29/32	2.5	2.135.013
30	430	600	29/32	2.5	2.135.014
40	1000	800	29/32	2.5	2.135.015

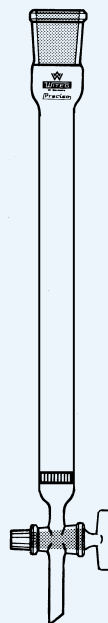

2.133.***

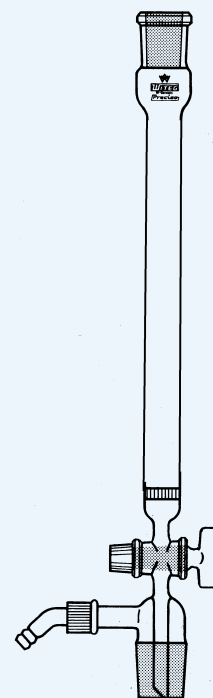

2.135.***

2.136.***

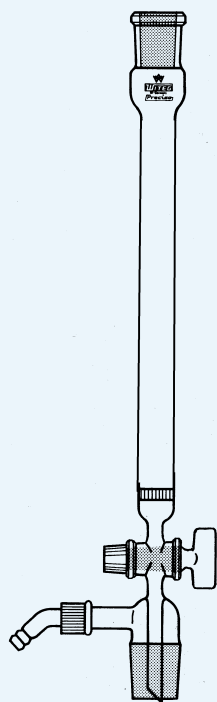

2.135.***
-
2.136.***

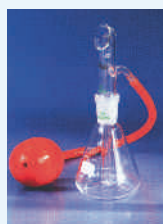

2.147.000



2.147.112



2.148.***

Chromatography-columns, with fused-in sintered glass-disc, P0, ST-PTFE-stopcock, with solid plug and screw-thread retaining nut, with vacuum connection and drip tip, made of borosilicate glass

Colonnes de chromatographie en verre borosilicaté avec verre fritté à porosité 0, robinet interchangeable à clé en téflon et raccord à vis pour vide

Column inner Ø Ø int mm	Column capacity Capacité ml	Effective length Longueur mm	Socket Cône femelle ST	Bore of plug Voie mm	Order No. N° de code
10	8	100	14/23	2.5	2.136.001
15	18	100	14/23	2.5	2.136.002
10	15	200	14/23	2.5	2.136.003
15	35	200	14/23	2.5	2.136.004
20	60	200	29/32	2.5	2.136.005
30	80	200	29/32	2.5	2.136.006
10	23	300	14/23	2.5	2.136.007
15	50	300	14/23	2.5	2.136.008
20	90	300	29/32	2.5	2.136.009
15	70	400	14/23	2.5	2.136.010
20	125	400	29/32	2.5	2.136.011
30	280	400	29/32	2.5	2.136.012
20	190	600	29/32	2.5	2.136.013
30	430	600	29/32	2.5	2.136.014
40	1000	800	29/32	2.5	2.136.015

Chromatography-columns, with fused-in sintered glass-disc P0, with PTFE needle valve stopcock, with vacuum connection and drip tip, made of borosilicate glass

Colonnes de chromatographie en verre borosilicaté avec verre fritté à porosité 0, vanne à clé en téflon et raccord à vis pour vide

Column inner Ø Ø int mm	Column capacity Capacité ml	Effective length Longueur mm	Socket Cône femelle ST	Bore of plug Voie mm	Order No. N° de code
10	8	100	14/23	2.5	2.137.001
15	18	100	14/23	2.5	2.137.002
10	15	200	14/23	2.5	2.137.003
15	35	200	14/23	2.5	2.137.004
20	60	200	29/32	2.5	2.137.005
30	80	200	29/32	2.5	2.137.006
10	23	300	14/23	2.5	2.137.007
15	50	300	14/23	2.5	2.137.008
20	90	300	29/32	2.5	2.137.009
15	70	400	14/23	2.5	2.137.010
20	125	400	29/32	2.5	2.137.011
30	280	400	29/32	2.5	2.137.012
20	190	600	29/32	2.5	2.137.013
30	430	600	29/32	2.5	2.137.014
40	1000	800	29/32	2.5	2.137.015

Sprayers for TLC chromatography, made of borosilicate glass, complete with rubber bulb

Vaporisateurs pour CCM, en verre borosilicaté, complet avec poire en caoutchouc

Type Type	Order No. N° de code
With erlenmeyer flask 100 ml, ST 19/26 <i>Avec fiole Erlenmeyer de 100 ml à RN 19/26</i>	2.147.000
With erlenmeyer flask 100 ml, ST 14/23, ball head <i>Avec fiole Erlenmeyer de 100 ml à RN 14/23</i>	2.147.100
With test tube 6 ml, ST 19/26, and base made of plastic <i>Avec tube à essai de 6 ml à RN 19/26 et base en plastique</i>	2.147.106
With test tube 12 ml, ST 19/26, and base made of plastic <i>Avec tube à essai de 12 ml à RN 19/26 et base en plastique</i>	2.147.112

Automatic capillary pipettes, Dr. Barrolier, error ± 1 %, made of borosilicate glass

Pipettes capillaires automatiques selon le Dr. Barrolier, tolérance +/-1%, en verre borosilicaté

Capacity Capacité ml	Order No. N° de code
1	2.148.001
2	2.148.002
10	2.148.010
20	2.148.020



Standard separating chambers, ground flange rim with ground knob-lid or with flat glass-lid, for TLC plates up to 200 x 200 mm, plane bottom, made of borosilicate glass

Cuves de développement CCM, type standard, avec couvercle à bouton ou avec couvercle plat, pour plaques CCM jusqu'à 200 x 200mm, en verre borosilicaté

Type	Order No.
Type	N° de code
Complete chamber <i>Chambre complète</i>	2.148.100
Chamber, without lid <i>Chambre sans couvercle</i>	2.148.101
Knobbed lid <i>Couvercle à bouton</i>	2.148.102
Glass cover plate <i>Plaque de fermeture en verre</i>	2.148.103



2.148.1**

Simultan separating chambers, made of borosilicate glass, with vertical grooves in the transverse walls to hold five TLC plates of 200x200 mm and is commonly used to wash TLC-plates before use and for the quantitative trace analysis

Cuves de séparation simultanée, en verre borosilicaté, avec rainures transversales pour 5 plaques CCM de 200 x 200mm et utilisées pour le lavage des plaques avant leur utilisation et pour les analyses quantitatives de traces

Type	Order No.
Type	N° de code
Simultan separating chamber with knob-lid <i>Cuve de séparation simultanée avec couvercle à bouton</i>	2.148.150
Simultan separating chamber with flat glass lid <i>Cuve de séparation simultanée avec couvercle plat en verre</i>	2.148.151
Spare knob-lid <i>Couvercle à bouton, de rechange</i>	2.148.152
Spare flat glass-lid <i>Couvercle plat en verre, de rechange</i>	2.148.153



2.148.15*

Nano-Separating chambers, made of borosilicate glass with lid made of stainless steel, for plates of 100 x 100 mm and 200 x 100 mm

Cuves de développement CCM, type Nano, en verre borosilicaté avec couvercle plat en acier inoxydable, pour plaques de 100 x 100 mm ou 200 x 100 mm

Type	Order No.
Type	N° de code
Nano-Separating Chamber 100 x 100 mm <i>Cuve type Nano, 100 x 100 mm</i>	2.148.200
Nano-Separating Chamber 200 x 100 mm <i>Cuve type Nano, 200 x 100 mm</i>	2.148.201



2.148.2**

Separating chambers - TLC, round with cap, made of borosilicate glass

Cuves de développement CCM, forme cylindrique avec couvercle, en verre borosilicaté

For plates	Diameter	Height	Order No.
Pour plaques	Diamètre	Hauteur	N° de code
mm	mm	mm	
200 / 50	60	230	2.140.720
200 / 100	130	230	2.140.730



2.140.7**



Colour comparing tubes *Tubes comparateur de couleur*

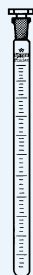

2.149.***

Colour comparing tubes,
acc. to Eggertz, with ST-stopper, made of
borosilicate glass

*Tubes comparateur de couleur d'Eggertz, avec
bouchon à rodage interchangeable, en verre
borosilicaté*

Capacity Capacité ml	ST RIN	Order No. N° de code
10 : 0.1	12/21	2.149.010
20 : 0.1	12/21	2.149.020
25 : 0.1	12/21	2.149.025
30 : 0.1	12/21	2.149.030
50 : 0.1	12/21	2.149.050
100 : 0.2	19/26	2.149.100

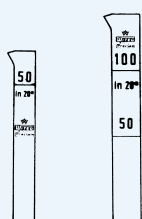

2.150.***

Color comparing cylinders,
acc. to Nessler, tall form, with optically
plane bottom, made of borosilicate glass

*Tubes comparateur de couleur de Nessler, forme
haute avec fond plan, en verre borosilicaté*

Capacity Capacité ml	Marks at Traits à ml	Height Hauteur mm	Outer Ø Ø ext. mm	Order No. N° de code
50	50	180	24	2.150.050
100	100	220	32	2.150.100
100	50 / 100	220	32	2.150.150

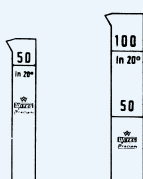

2.151.***

Colour comparing cylinders,
acc. to Nessler, short form, with optically
plane bottom, made of borosilicate glass

*Tubes comparateur de couleur de Nessler, forme
basse avec fond plan, en verre borosilicaté*

Capacity Capacité ml	Marks at Traits à ml	Height Hauteur mm	Outer Ø Ø ext. mm	Order No. N° de code
50	50	150	26	2.151.050
100	100	180	34	2.151.100
100	50 / 100	180	34	2.151.150

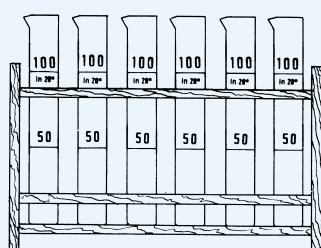

2.152.***

Support, made of wood, for colour
comparing cylinders, acc. to Nessler

Support pour tubes de Nessler, en bois

Type Type	Order No. N° de code
For 6 cylinders, tall form / <i>Pour 6 tubes à forme haute</i>	2.152.001
For 12 cylinders, tall form / <i>Pour 12 tubes à forme haute</i>	2.152.002
For 6 cylinders, short form / <i>Pour 6 tubes à forme basse</i>	2.152.003
For 12 cylinders, short form / <i>Pour 12 tubes à forme basse</i>	2.152.004

Micro distilling apparatus *Appareil de micro-distillation*

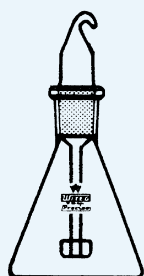

2.154.***

Micro distilling apparatus, Widmark,
for determination of alcohol in blood,
made of borosilicate glass

*Appareil de micro-distillation selon Widmark,
pour la détermination de l'alcool dans le sang, en
verre borosilicaté*

Type Type	Order No. N° de code
Complete / <i>Complet</i>	2.154.000
Spare parts / Pièces de rechange	
Erlenmeyer flask, 50 ml, ST 19/26 <i>Fioule Erlenmeyer de 50 ml, RN 19/26</i>	0.620.050
Adapter with ST 19/26 <i>Fioule Erlenmeyer de 50 ml, RN 19/26</i>	2.154.002